

# Howard County Department of Recreation & Parks

## TRAIL PLANNING AND MANAGEMENT GUIDE

November 2017  
Version 171115

Howard County, Maryland  
Office of Purchasing  
6751 Columbia Gateway Drive, Suite 501  
Columbia, Maryland 21046



This Trail Planning and Management Guide was prepared for the Howard County Department of Recreation & Parks by;



PENN TRAILS LLC  
PO Box 1337  
Carlisle, PA 17013  
[717] 486.4455

[info@penntrails.com](mailto:info@penntrails.com)    [www.penntrails.com](http://www.penntrails.com)

This publication was funded through the HCRP Bureau of Capital Projects, Park Planning and Construction.

This document was developed for electronic distribution and contains embedded url hyperlinks to external Howard County Department of Recreation & Parks reference documents. To download the electronic version of this document, and find other related documents, visit <https://www.howardcountymd.gov/Departments/Recreation-and-Parks/FormsandPublications>

The Trail Planning and Management Guide is advisory in nature, and no guarantee or warranty, express or implied, is given as to the accuracy, reliability, currency, or completeness of its contents. The authors accept no responsibility for any adverse effects or consequences, loss, or damage occasioned by the use of the Trail Planning and Management Guide.

Photo Credits:

- Center ..... Howard County Department of Recreation & Parks
- Bottom Left.....Penn Trails LLC
- Bottom Center ..... Penn Trails LLC
- Bottom Right .....Howard County Department of Recreation & Parks
- All other photos herein ..... Penn Trails LLC and Howard County Department of Recreation & Parks

Penn Trails acknowledges and thanks the following subcontractors who assisted in this document's preparation;



P.O. Box 31, Accord, NY 12404    (845) 591-1537  
[tahawustrails@gmail.com](mailto:tahawustrails@gmail.com)    [www.tahawustrails.com](http://www.tahawustrails.com)



7402 York Rd #201, Towson, MD 21204    (410) 296-3990  
[liling@peladesign.net](mailto:liling@peladesign.net)    [www.peladesign.net](http://www.peladesign.net)



5920 Hamilton Boulevard, Ste 108, Allentown, PA 18106-8942  
(610) 395-9222    [www.hanovereng.com](http://www.hanovereng.com)



P.O. Box 47435, Forestville, MD 20753    (301) 856-9319  
[scook@wscassociates.com](mailto:scook@wscassociates.com)    [www.wscassociates.com](http://www.wscassociates.com)

## TABLE OF CONTENTS

Section I - Howard County Trails.....	5
Introduction.....	6
Purpose.....	6
Howard County Department of Recreation & Parks.....	7
Trail Policy and Program Mission .....	7
Trail Regulations.....	7
Principles of Sustainability .....	7
Creating and Maintaining Enjoyable Trail Experiences .....	8
Recreational Programming .....	8
Providing Universal Access .....	9
Collaboration with Other County Departments .....	9
Collaboration with Community Partners and Volunteers .....	11
Section II - Trail Planning and Development .....	12
Trail Project Permitting.....	13
Wetlands and Floodplains.....	13
Forest Conservation .....	16
Wildlife Management and Rare, Threatened, and Endangered Species .....	17
Historic Resources .....	18
Erosion & Sedimentation Controls .....	19
Utilities, Rights-of-Way, Easements, and Setback Requirements .....	37
Design and Development Procedures .....	38
Trail Planning and Management Fundamentals.....	39
Trail Design Parameters.....	43
Trailheads.....	45
Site Planning .....	46
Site Selection .....	48
Site Design.....	51
Trail Documentation & Mapping Standards.....	60
Section III - Trail Maintenance.....	63
Trail Monitoring.....	66
Maintenance Scheduling and Documentation.....	66

Trail Closures.....	68
APPENDICES .....	71
APPENDIX I: Howard County Trail Design Parameters .....	72
APPENDIX II: Trail Assessment Form.....	76
APPENDIX III: Trail Proposal Form .....	77
APPENDIX V: Federal Trail Data Standards (“FTDS”) For Trail Class .....	82
APPENDIX VI: Trail Signage and Wayfinding .....	84
APPENDIX VII: Typical Design Guides For Planning, Construction and Maintenance.....	85
APPENDIX VIII: Trail Bridges.....	86
APPENDIX IX: Terms and Definitions.....	86

# Section I - Howard County Trails

# FOREWORD

## Introduction

It is hard to argue against the benefits of trails. They provide a vital connection to our well-being whether it is from a health and fitness point of view or from the conservation and appreciation of the environment and historic resources we enjoy, trails support strong communities and enhance the quality of life in Howard County.

Most of the lands managed by the Department of Recreation & Parks have a trail network, either planned or unplanned. In many cases, the network is substantial and has been in place for some period of time. The Department is responsible for assessing existing conditions, upgrading and improving the management of existing trail systems and determining where the construction of new trails and shared use paths will be necessary to meet user demands or to protect resources.

The vision and goals of the Department of Recreation & Parks flow directly from the 2017 Howard County Land Preservation & Recreation Plan<sup>1</sup>. This plan is required by the State of Maryland and it allows the County to remain eligible for Program Open Space funds. This program is the primary source for park land acquisition. The 2017 Land Preservation & Recreation Plan was created in cooperation with the Department of Planning & Zoning, Maryland Department of Natural Resources, Sasaki Associates, Inc. It describes how Howard County intends to continue developing its recreation-related resources without compromising sensitive natural resources and conserves the region's farmland.

The Land Preservation & Recreation Plan is also closely aligned with the County's General Plan - Plan Howard 2030. This document is Howard County's 20 year comprehensive plan update. It highlights key issues and goals for future planning efforts in the County and addresses the three key aspects of sustainability – the environment, the economy and community quality of life.

## Purpose

The purpose of this Best Management Practices for Trail Guideline document is to offer consistency to the entities within the County who contribute to the planning, design, construction and management of natural surface trails. This includes County agency personnel, developers, and organized volunteer groups. It will assist with describing terminology, trail planning and management fundamentals, and provide a standard to ascribe trail planning decisions against. Essentially, this document was created to help the County achieve its mission.



---

<sup>1</sup> This document is currently in the process of update by a consultant due to be completed in July 2017

The purpose of the Department of Recreation & Parks trail system is to:

- Provide opportunities for all people to recreate safely in a natural setting without causing damage to the resources.
- Provide opportunities to stimulate and accommodate public interest in wildlife conservation, habitat restoration, historic and cultural resources through controlled access.
- Provide alternative transportation corridors.

## **Howard County Department of Recreation & Parks**

### *Department of Recreation & Parks – Vision Statement*

The Department strives to deliver recreation and leisure opportunities that will improve the health and well-being of the community and to serve as model stewards of the environment by managing, protecting, and conserving our resources for a sustainable future.

### *Department of Recreation & Parks – Mission Statement*

The Department will strive to:

- Responsibly manage natural resources;
- Provide excellent parks, facilities, and recreation opportunities for the community; and
- Ensure the highest quality of life for current and future generations.

## **Trail Policy and Program Mission**

The Department of Recreation & Parks has developed a Trail Management Policy that provides guidance for trail planning, design, construction and management. It was created by an internal committee, the Trail Network Team, and contains representation from both the Bureau of Parks and the Bureau of Recreation. These individuals actively maintain and program the trails within the Howard County Trail System.

## **Trail Regulations**

The planning, development, construction and management of trails in Howard County must be consistent with the mission, vision, goals, plans, and regulations with the County government, and any applicable State and Federal regulations.

## **Principles of Sustainability**

Sustainable trails don't just happen. A trail that captures a sense of place and experience, while minimizing the ecological impact on the landscape, can only occur through thoughtful planning, good design, accurate layout and installation.

Many of the trails that occur on County lands suffer from lack of planning, poor design or no maintenance. Trails that are "user defined" or leftover from previous land uses have left the Department struggling with trails that require a significant investment in time and money to maintain and do not meet the needs of the user or protect the surrounding natural resources.

A sustainable trail, planned correctly from the beginning, will require minimal maintenance over extended periods of time. In addition, it will meet the recreational needs of the present generation without compromising the ability of future generations to meet their own recreational needs. This is at the core of understanding, implementing and maintaining sustainability within the County trail system.

A sustainable trail is one that is planned and constructed to be physically, ecologically, and economically sustainable:

- Physical Sustainability  
Designing trails to retain their structure and form over years of use and under forces of humans and nature is a key factor in sustainability. The more a trail is utilized by people, the more it is susceptible to wear and tear. Thus, a trail must be designed with anticipated usage in mind, to ensure that it remains physically stable with appropriate maintenance and management.
- Ecological Sustainability  
Minimizing the ecological impacts of trails, and protecting sensitive natural and cultural resources is fundamental in sustainable trail design and development.
- Economic Sustainability.  
For any trail, the implementing agency or advocacy group must have the capacity to economically support it over its life cycle. Developing and committing to a long-term maintenance strategy is a critical aspect of a successful trail program.
- Recreational sustainability  
Trails that promote recreational sustainability are designed to maximize the useful life of recreation facilities and providing recreational opportunities into the future, thereby encouraging self-supporting design, maintenance, operation, and funding.

### **Creating and Maintaining Enjoyable Trail Experiences**

As stated earlier, many existing trails that occur on County land/property have been developed over time without careful planning and/or proper construction. These trails often have persistent maintenance and safety issues, user conflicts, or unacceptable environmental impacts. Trails that are “user defined” or leftover from previous land uses have left the Department struggling with a significant investment in time and money to maintain such trails, which do not meet the needs of current or future users, and impact adjacent county natural resources and assets.

In December 2014, the Department of Recreation & Parks released a Trail User Survey in an attempt to capture a sense of who our trail users are, what types of activities they use our trails for, and to see if these trail users would like to volunteer to help maintain trails. This type of management tool will be incorporated into the overall trail system management program.



### **Recreational Programming**

The Department hosts numerous community sponsored events involving trails including, but not limited to, walk-a-thons, 5K races, triathlons, cycle-cross, and a mountain bike epic. In addition, the Department also sponsors a variety of trail-based recreational programs such as mountain bike camps, bird watching, and environmental education experiences. All of these types of events and programs need to be incorporated



into the overall management scheme of the County trail system to ensure adequate accommodations, safety, and resource protection.

### Providing Universal Access

As stated previously, the purpose of the Department of Recreation & Parks trail system is to provide opportunities for all people to recreate safely in a natural setting without causing damage to the resources.

The Department will be incorporating 2013 ABA Outdoor Developed Areas Accessibility Guidelines (ODAAG) for Trails & Trailheads. The ODAAG provides an excellent roadmap for private entities and local government agencies that want to design and build hiker/pedestrian trails that offer universal accessibility.



In 2013, the U.S. Access Board<sup>i</sup> issued the *Outdoor Developed Areas Accessibility Guidelines*<sup>ii</sup> (<https://www.access-board.gov/guidelines-and-standards/recreation-facilities/outdoor-developed-areas/final-guidelines-for-outdoor-developed-areas>)<sup>iii</sup> (ODAAG) and in 2014 published its own guide, *Outdoor Developed Areas: A Summary of Accessibility Standards*.<sup>iv</sup>

While ODAGG is not binding on non-federal organizations or agencies, the Howard County Department of Recreation & Parks recommends that county agencies and organizations, as well as private developers, utilize Chapter 1017 “Hiker and Pedestrian Trails” of the Outdoor Guidelines as Best Management Practices considerations for their trail planning, design, construction and maintenance. These guidelines are not applicable to trails *primarily designed* for use by equestrians, mountain bicyclists, or off-highway vehicle users, even if pedestrians may use the same trails.

### Collaboration with Other County Departments

The Mission of Department of Planning & Zoning - To help shape positive change in Howard County by facilitating the development of safe, healthy, equitable, connected, and sustainable communities; while concurrently respecting individual rights and protecting the County’s natural environment and its historical integrity.

#### *Howard County Office of Transportation*

County agency responsible for developing and implementing the Bicycle and Pedestrian Master Plans. The General Plan - PlanHoward 2030, calls for the promotion of complete streets design practices, and establishment of an interdepartmental team to implement both a countywide Bicycle Master Plan - **BikeHoward** and a countywide Pedestrian Master Plan – **WalkHoward**. Although this guide deals primarily with natural surface trails and the Bicycle and Pedestrian Master Plans will deal primarily with shared use pathways, there will be occasions when the Bike and Pedestrian Master Plans interface with natural surface trails connections or access points and trailheads.

**BikeHoward** is the Howard County Bicycle Master Plan. The primary purpose of **BikeHoward** is to provide a framework to guide the county’s future actions and investments to improve conditions for bicyclists and promote bicycling as a safe and convenient travel option.

By improving conditions for cyclists on roadways, by connecting and extending paths, and by linking residential areas to shopping centers, public facilities and jobs, bicycling can take its place in an effective multi-modal transportation system that provides residents sustainable transportation options for daily life.

### Vision

The Vision for both the BikeHoward and WalkHoward plans can be accessed on the County's websites articulated below:

*Howard County, Maryland seeks to be a bicycle-friendly County where residents and visitors, schoolchildren and seniors, men and women feel comfortable and safe bicycling on our roads and paths as a means of daily transportation and healthy recreation.*

### Goals

- Create a Safe and Seamless Network: For bicycling to grow, cyclists must have a safe and seamless network of bikeways that connects them to where they want to go: schools, shops, parks and work, with facilities that will serve cyclists of all skill and comfort levels.
- Increase Participation and Safety through bicycle educational programs for school-aged children and youth, and awareness campaigns for motor vehicle users.
- Update County Policies to ensure that that the County's infrastructure and land development policies fully accommodate and encourage bicycling.
- Coordinate with Maryland state legislators and agency officials to accommodate bicycle travel through: state highways and public transit services, regulation of utility rights-of-way, administration of storm water treatment and water quality regulations
- Promote Active Living by including bicycling as an active component of a livable community that is physically healthy, economically sound and environmentally sustainable.



**WalkHoward** is the Howard County Pedestrian Master Plan. The primary purpose of **WalkHoward** is to provide a framework to guide the county's future actions and investments to improve conditions for pedestrians and promote safe and convenient travel options.

## Collaboration with Community Partners and Volunteers

Trails, in particular, offer an avenue for encouraging volunteerism and stewardship within our parks. Most trail users love to volunteer to maintain the trails they use and trail management can greatly benefit from volunteers. User groups can help create, maintain, restore, or close trails. However, to be effective, volunteerism must be guided, directed, and managed.

The Department of Recreation & Parks does not have a Volunteer Coordinator responsible for organizing and directing volunteer trail projects. Although, some small, organized trail maintenance events have occurred sporadically over the past few years, the desire is to hire additional personnel to organize more frequent trail maintenance events, adopt-a-trail opportunities, and the formation of an advocacy “Friends of Group” to raise money and advocate for funding of trail projects in the County.



# Section II - Trail Planning and Development

## Trail Project Permitting

Any disturbance to the natural environment has impacts, and trails are no exception to this rule. Ideally trails should be routed to avoid sensitive areas like wetlands, stream sides, rare species habitat, steep slopes, etc. However, trail development into portions of these areas is often necessary and justifiable. When these cannot be avoided, there are legal and ethical obligations to minimize impacts by going through the proper regulatory procedures. The following are a summary of the current County regulations that affect trail development.

### Title 16. Planning, Zoning and Subdivision and Land Development Regulations

- Section 16.115 Floodplain preservation (c)
- Section 16.116 Protection of wetlands, streams, and steep slopes (a) (b)
- Section 16.117 Forest conservation and preservation of natural cover
- Section 16.118 Protection of historic resources

HOWARD COUNTY DEPARTMENT OF PERMITTING, LICENSES & PERMITS 149 COCKETT ROAD BELLICOTT CITY, MD 21045		LICENSES & PERMITS (410) 313-2451 INSPECTIONS (410) 313-1551	
<b>APPLICATION FOR GRADING PERMIT</b>			
SITE ADDRESS: 8971 Haviland Mill Road City: Clarksville State: Maryland ZIP: 21029		CONTRACTOR: HTI Contractors ADDRESS: 4538 BARKSBILLE ROAD FARMERSVILLE MD 21046	
SUBDIVISION: N/A TAX MAP: 0000 ACREAGE: 33.45 acres GRID: 0001		CITY: ZIP: STATE: COUNTY: 410-313-2451	
PARCEL: 0528 SECTION: N/A ZONE: RR-DFO Rural AREA: 1.467 ACRES CENTER TRACT: 864103 SDP: N/A		OWNER'S NAME: Howard County Government DRP ADDRESS: 7122 Oakland Mills Road COLUMBIA, MD 21046 PH: 410-313-0699 (WORK) (HOME)	
Existing Use: Residential		***** PRIOR APPROVALS REQUIRED ***** (ATTACH COPIES OF ALL APPLICABLE APPROVALS)	
Proposed Use: Residential		Developer Agreement No. Due Date: / /	
Proposed Work: Construction of a recreational pedestrian trail		Forest Conservation Agreement No. N/A	
Total Area Disturbed (Average 1/4th) 21,345 s.f. (1.49 acres)		MDE Wetway Construction Permit No. 14-NT-3282201461442	
Total Site Area (Average 1/4th) 83,638 s.f. (1.92 acres)		MDE Non-Tidal Wetland Permit No. 14-NT-3282201461442	
Cost of Work \$ 805,000.00		MDE Water Quality Certification 14-NT-3282201461442	
Map Number P 1807 / GP ECP-18-022		MDE Notice of Intent No. N/A	
Grading Survey Amount \$ County Project - Exempt from fees		US Army Corps of Engineers	
Utility Trenching (F) N/A		Wetland Permit No. 201461442	
Wetland Code: JWP			
I CERTIFY THAT THIS APPLICATION IS CORRECT AND I HAVE THE AUTHORITY TO MAKE SUCH APPLICATION, AND I AGREE TO COMPLY WITH ALL REQUIREMENTS OF TITLE 3, SUBTITLE 4, OF THE HOWARD COUNTY CODE.			
Signature - Owner/Authorized Agent rdelorme@howardcountymd.gov		(Date)	
Road Districts 7120 Oakland Mills Road City: Columbia State: Maryland Zip: 21045		410.313.4699	
Name (print)		Phone	
DEPT OF PLANNING & ZONING LAWSON-CORREY BUILDING (300A)		FOR OFFICE USE ONLY	
AMOUNT \$			
FOR FOREST CONSERVATION, WETLAND, STREAM, STEEP SLOPE VERIFICATION		INITIALS DATE	
PROPERTY ID NO.		CASH RECEIPT NO. #	
GRADING PERMIT NO.		APPROVED: SIGNATURE DATE	
DATE RECEIVED:			
PREPARED BY:			
CHECKED BY:			
VALIDATION NUMBER:			
CODES: WHITE - DEP YELLOW - SHEDDING CONTROL PINK - FINANCE		Issued Oct. 1, 2009 (Form 6) GRADING PERMIT 3.0 (1/09)	

## Wetlands and Floodplains

Wetlands are unique ecological systems and may in fact become control points (both positive and negative) during trail development. Wetlands are also very important natural resources that are responsible for filtering pollutants from surface runoff, provide flood control and water storage capacity, and provide important habitat for flora and fauna. Due to their significance as important resources, their protection is critical and therefore regulated by both the U.S. Army Corps of Engineers (USACE) and the State of Maryland.

Wetlands in the State of Maryland are regulated by Maryland's Department of the Environment (MDE) through the Environment Article Title 5, Subtitle 5-901 through 5-911; Annotated Code of Maryland: COMAR 26.23. MDE is responsible for regulating any of the following activities within wetlands:

- Grading or filling
- Excavating or dredging
- Changing existing drainage patterns
- Disturbing the water level or water table
- Destroying or removing vegetation

Additionally, MDE will work in conjunction with the USACE for any impacts to jurisdictional waters (Water of the U.S.). MDE will be responsible for permitting impacts to Waters of the State. If there are proposed impacts to Waters of the U.S. that require a permit directly from the USACE, that permit coordination will be done by MDE.

Linear projects, specifically trail projects, are generally difficult to design without requiring water dependency, meaning, the development of the trail cannot function without direct access to a regulated water body, e.g. wetlands or watercourses. It is critical for the trail designer/planner to first implement avoidance measures followed secondly by minimization efforts in the trail design. If impacts to water bodies are unavoidable, minimization is of utmost importance. The regulator will question the need for impacts

and expect the designer or person responsible for permitting the activity to provide reasonable and just cause of why the impacts are necessary.

Identifying regulated water bodies should occur early in the design process and should be performed by persons with experience in wetland delineations. By identifying regulated features early in the design process, the features can be avoided and minimized to the maximum extent practicable. Conversely, if the trail corridor is established and then the corridor is delineated, a complete realignment may be necessary in order to justify and/or meet avoidance measures requested by regulators.

Once regulated wetland boundaries are identified, it will then be necessary to determine the appropriate regulated wetland buffer. Wetland buffers of 25 feet are regulated by MDE and will require authorization for any activity that impacts the buffer. Wetlands classified as “Special Concern” in COMAR 26.23.06 will require buffers of 100 feet. It is important to account for wetland and buffer impacts when aligning the trail. Significant revisions may have to be made in order to avoid and minimize impacts to both wetland boundaries and applicable buffers.

Impacts to wetlands and/or wetland buffers may be considered de minimus, temporary, or permanent. Careful consideration and design measures should be implemented to avoid any impacts to wetlands and/or wetland buffers. Furthermore, all wetland impacts will require costly mitigation and permanent wetland impacts will be difficult to justify from a permitting perspective.

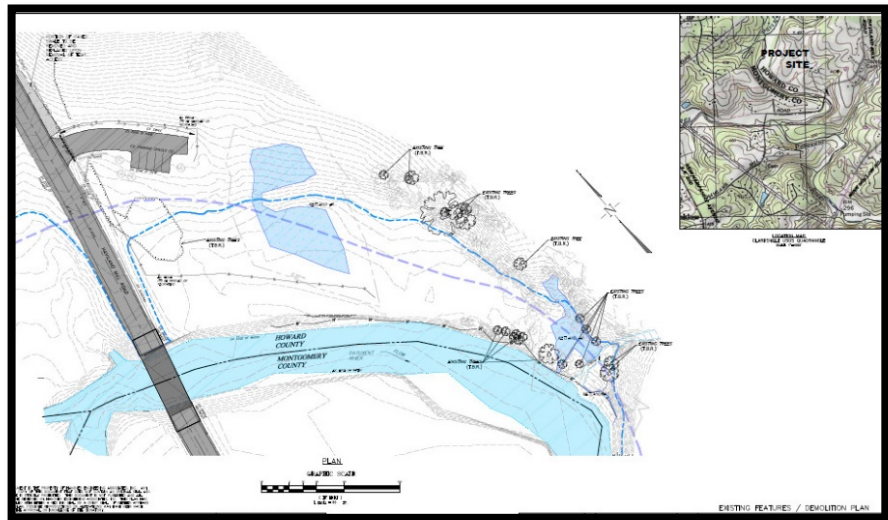

Therefore, it should be the goal of all trail professionals to design trails with **no** impacts. This will not only save permitting time and mitigation, but results in an ecologically responsible design. If avoidance is not possible due to site constraints, the use of structures in a trail design can minimize impacts. Structures such as elevated boardwalks utilizing helical piers can be designed in a manner to avoid impacts when properly designed, avoid lengthy permitting delays, and allow trails to be permitted under an MDE Letter of Authorization (LOA). LOAs may be issued in as little as 30-60 days. The regulator responsible for wetlands in the County will offer advice and design criteria in order to meet possible LOA authorizations.

In the event wetlands cannot be avoided, the type of impact will determine the length of acquiring necessary permit authorizations. MDE categorizes projects as either Minor or Major Projects. Minor Projects typically involve permanent impacts of less than 5,000 square feet to nontidal wetlands or less than one acre of isolated nontidal wetland. Major Projects involve permanent impacts of greater than 5,000 square feet to nontidal wetlands; or projects with less than 5,000 square feet but within Critical Area, a Nontidal Wetland of Special State Concern, or within a Use III or IV watershed. It is important to note there are no tidal wetlands in Howard County, so wetlands will always be classified as nontidal. Minor Projects and Major Projects can reasonably expect a minimum of 10 months and 12 months respectively for permit authorization. Permitting steps are explained later in this section.

Construction activities in waterways and 100-year floodplains (an area with a 1% annual probability/risk of being flooded) also require permitting through the USACE and/or MDE. Waterway construction regulations assure activities in a waterway or its floodplain will not create flooding on upstream or downstream property, maintain fish habitat and migration, and protect waterways from erosion. Similarly to wetland identification, waterways and the associated 100-year floodplain (as determined by FEMA) should be identified early in the design process and should be avoided to the maximum extent practicable. When waterways and floodplains cannot be avoided by the trail corridor, appropriate structures must be designed to minimize the trail's impact to the waterway and/or the 100-year floodplain.

MDE also categorizes waterway and 100-year floodplain projects as either Minor or Major Projects. Minor Projects typically involve: minor repair or maintenance; temporary construction; clearing and grading activities in the 100-year floodplain that involve less than 100 cubic yards of disturbance; or, minor changes or modifications to existing permits. Major Projects are projects that propose permanent impacts to: construct, reconstruct a reservoir, dam, or other waterway obstruction; construct a waterway; or dredge, fill, bulkhead or change the shoreline. Minor Projects and Major Projects can reasonably expect a minimum of 10 months and 12 months respectively for permit authorization. Again, it is important to note certain design elements may be proposed for a trail project that would result in virtually no impacts and an authorization in the form of a LOA. Single-span bridges from top-of-bank to top-of-bank, as opposed to a trail constructed with culverts, will typically result in zero impact. It is imperative to discuss possible construction alternatives, especially if a budget or timeframe is severely constrained.

It is also important to know and understand Maryland's stream classifications, specifically Tier classifications, as they will likely require special considerations for permitting as regulated in COMAR 26.08 Water Pollution and COMAR 26.17.04. Tier III waters are considered Outstanding National Resource Waters and require the most stringent protection. Tier III is currently under development by MDE. Tier II waters are waters that biologically exhibit water quality characteristics that exceed the minimum requirements specified by the water quality standards.



Potential impacts to Tier II waters will require anti-degradation review and social and economic justification for MDE to assess during permit consideration. Additionally, expanded buffers and strict erosion and sedimentation controls may be required during development and construction of the trail project. The applicant will be required to work closely with MDE to resolve any potential issues or impacts associated with Tier II waters. The list of Tier II streams/segments is updated periodically and should be reviewed as early in the design process as possible. The list can be found in COMAR 26.08.02.04.1. All other waters are Tier I.

In addition to Tier classifications, MDE has implemented a surface water "use" designation system as well. The use class is a grouping or set of designated uses that apply to a water body which individually may or may not be supported now, but should be attainable. The use class does not affect permitting quite as much as the Tier classifications, but will be required to list on permitting documents and certain uses may be subject to seasonal construction restrictions as deemed necessary by MDE.

Impacts to wetlands, wetland buffers, waterways, and floodplains are permitted simultaneously through MDE during the approval process. It is strongly encouraged to request MDE to participate in a Pre-Application Meeting. MDE assigns specific representatives to each county and these are the people with whom applicants will contact regarding all projects in that respective county. The advantage of requesting a Pre-Application Meeting is to provide the opportunity to present the project directly to the MDE persons responsible for making permit decisions. A list of County contacts is available at: <http://www.mde.state.md.us/programs/Water/WetlandsandWaterways/Pages/WetlandsAndWaterwaysProgramDirectory.aspx>.

Upon completion of the Pre-Application Meeting, the applicant should have a clear permitting path forward, know exactly what MDE is requiring from a permitting perspective, and know what type of authorization will be required. At that point, any required revisions can be made to the project plans and the “Joint Federal/State Application for the Alteration of any Floodplain, Waterway, Tidal or Nontidal Wetland in Maryland” form and required documents can be submitted to MDE. If necessary, MDE will forward the necessary paperwork to USACE for permit coordination at this time.

### **Forest Conservation**

In the 1991 session, the Maryland General Assembly passed the Forest Conservation Act (SB 244), a law requiring all local jurisdictions to establish and enforce controls on the disturbance of wooded areas when properties are developed. The Act has been incorporated in the Annotated Code of Maryland as Natural Resources Article, Section 5-1601 to 5-1603. Any activity requiring an application for a subdivision, grading permit, and/or sediment control permit on areas one (1) acre or greater is subject to the Forest Conservation Act and will require a Forest Conservation Plan prepared by a licensed forester, licensed landscape architect, or other qualified professional.

As required by law, Howard County developed a Forest Conservation Manual, which is enacted through Howard County, MD Code of Ordinances Subtitle 12. – Forest Conservation. In short, the Forest Conservation Act aims to:

- Keep intact as much of the existing forest resources as possible when developing a site (retention).
- Replant woodlands if trees must be cleared (reforestation).
- Plant new forest stands to create the minimum level of forest cover specified on sites where no or very limited forest resources exist (afforestation).



Trail projects do not result in the same type of earth disturbance, including tree removal, as other types of development projects. In fact, trees are often positive controls points within the trail corridor and careful planning and design ensures trees are both implemented into the aesthetics of the trail and construction methods are designed to protect the trees. However, there are occasions where trail corridor constraints make tree removal necessary. For example, tree risk assessments are helpful in determining if certain dead/dying trees will pose as a risk to trail users. In such a case, trees may be removed for safety as opposed to being removed because they are simply *in the way*. Emphasis should always be placed on limiting and minimizing the amount of trees removed and making sure trees of significance are retained.



Most, if not all trail projects, permitted through Howard County will require grading permits, and as such, should be required to adhere to the Forest Conservation Act. There are however, a few exceptions defined in Section 16.1202(b) of the County Code that may apply to specific projects. It is important for applicants to check the list of exceptions to see if the project is exempt and file the required Declaration of Intent. The Declaration of Intent serves as a written reminder to all parties that the exemption from forest conservation obligations is contingent on no subsequent activity regulated by the forest conservation program occurring within 5 years of completing the exempted activity.

If the project does not meet the exceptions, the applicant shall follow the Forest Conservation Act and prepare the required forest stand delineation. The forest stand delineation includes, but is not limited to, identification of State Champion Trees, trees 75% of the size (diameter) of State Champion Trees, and trees 30" in diameter or larger; steep slopes (25% and greater and 15-25%); critical habitats (as made available by the Natural Heritage Program); Perennial and Intermittent streams and stream buffers; nontidal wetlands and buffers; existing buildings, adjacent land uses, etc. The forest stand delineation then becomes part of the Forest Conservation Plan.

The Forest Conservation Plan shows how a proposed development addresses the retention priorities of the forest conservation program, how forest conservation is coordinated with other subdivision or site development requirements, whether the proposal requires any reforestation or afforestation, and if so, where and how such new planting will be done.

It is important to stress that although typical trail projects will require grading permits, thereby requiring the need for a Forest Conservation Plan, applicants should work closely with the County, particularly the Division and Land Development (DLD) to address this requirement. Due to the general nature of trail projects and the limited amount of earth disturbance and tree clearing necessary for trail development and construction, concessions may be considered to limit the amount of work necessary to meet this requirement. For example, DLD may consider limited forest delineations within a certain offset of the trail centerline, stipulations made to strict working corridors, specific identification of any trees to be removed, etc.

### **Wildlife Management and Rare, Threatened, and Endangered Species**

Wildlife management is essentially the science that balances wildlife and people. It involves both the protection of species and critical habitats and the population management of species that have become too abundant for current habitats. This science has been tested in the last century and has become quite an endeavor to manage. Habitat destruction and consequently the loss of suitable habitat has been at the forefront of debates relating to wildlife management. The loss of habitat results in both an increased number of fauna in developed and urban areas and more species that can no longer survive without certain habitat. The abundant populations are conflicting with humans, the fauna begin developing diseases, and animals and people are harmed because of the displacement. More species are also becoming vulnerable and are listed as species of concern due to dwindling populations or worse yet, listed as threatened and endangered because mortality rates have increased exponentially.



Trail projects tend to result in very little, if any, habitat destruction if they are planned, designed, and constructed properly. They also offer opportunities for users to see flora and fauna in their natural habitats.

Trail development aids in the preservation of open spaces, helps protect critical habitat, and provides unique environmental education opportunities.

The protection of rare, threatened, and endangered species is a serious concern and is regulated by Maryland Law (Nongame and Endangered Species Conservation Act (Annotated Code of Maryland 10-2A-01)) and Federal Law (Endangered Species Act of 1973). Maryland law requires that all state agencies conserve and protect native plants and animals that are listed as endangered, threatened, or in need of conservation. The Maryland Department of Natural Resources (MDNR) oversees and manages this law through the Wildlife and Heritage Service Natural Heritage Program.

The Maryland Natural Heritage Program offers public information regarding the potential conflict of rare, threatened, or endangered species through MERLIN Online and the Sensitive Species Project Review Areas (SSPRA). MERLIN Online is an internet based tool that allows users to pre-screen project areas to determine the possibility of potential conflicts. In addition to the information available on MERLIN, there is a data layer that is available by request from the Wildlife and Heritage Service. The data layer provides an overview of nearly all state-regulated and designated areas involving sensitive and listed species.

During the initial stages of trail development, it is important to utilize either of the tools listed above to screen the project area for potential conflicts. It is even more important to initiate consultation with MDNR and the U.S. Fish and Wildlife Service as soon as possible. The screening tools are to be used as guidance tools only. Any required permitting for the project will require proof of consultation and clearances from both agencies listed above before permitting decisions will be made.

The importance of pre-screening will allow trail developers to have an idea of whether potential conflicts exist and they can use that knowledge to their benefit when assessing potential corridors and determining alignments. It is also important from a permitting perspective to know whether or not botanical studies will have to be undertaken and knowing when those studies will have to occur, e.g. during flowering periods only, during the growing season, etc. Projects have been delayed for an entire year because a project resulted in a potential impact to a plant species that can only be identified in the summer and applicants consulted with the proper agencies in October.

A list of Current and Historical Rare, Threatened, and Endangered Species is available by County at: [http://dnr2.maryland.gov/wildlife/Pages/plants\\_wildlife/rte/rteplants.aspx](http://dnr2.maryland.gov/wildlife/Pages/plants_wildlife/rte/rteplants.aspx)

## Historic Resources

Historic and cultural resources include historic sites and archaeological sites comprised within County parks. People are drawn to these sites out of curiosity and/or for educational experience. The general recommendation is to create as little impact or disturbance to the cultural resource as possible. Therefore, thorough consideration as to why a trail needs go to or cross the cultural resource to begin with needs to be addressed. Can the trail be located somewhere else? When it is determined necessary to access the cultural resource, the same considerations apply. In some instances, the Maryland Historical Trust may need to be consulted i.e. identified Historic Districts on zoning maps and historic sites designated by resolution of the County Council.



## Erosion & Sedimentation Controls

### *Introduction*

Controlling erosion and sedimentation is a key factor in the longevity and sustainability of any trail surface. The trail designer should first understand what erosion and sedimentation are and how they occur in order to properly manage them.



Soil erosion is the process of wind, water, ice or gravity wearing away the earth's surface. Soil particles from the erosion process are then transported and deposited to downslope/downstream locations. This overall process is known as sedimentation. Though it is a natural step in the earth's current formation, erosion and sedimentation can often result in both environmental and economic impacts, and not to mention the destruction of our trails. The trail designer must have an understanding of the types of erosion and the factors primarily affecting the rate of erosion and sedimentation. This knowledge can be implemented during the trail's initial layout and design phase to prevent erosion and sedimentation before it begins.

Water-generated erosion is the most severe type of erosion and therefore it is the trail designer's priority to address runoff and direct water away from the trail. Water-generated erosion begins with raindrops falling on unprotected soil surfaces and increases due to frictional forces as rain droplets combine and flow across land.

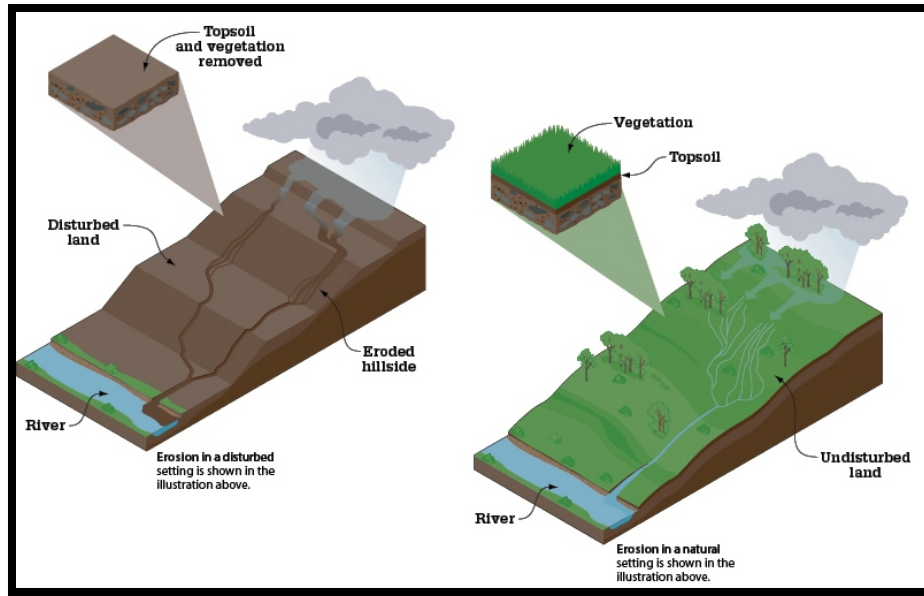

Four basic factors determine a surface's potential for erosion: soil characteristics, vegetative cover, topography, and climate. Soil characteristics which influence soil erodibility are those which affect infiltration capacity and resistance to detachment by falling or flowing water. Soils with high percentages of fine sand and silt content are typically the most erodible. Increasing the clay and organic matter decreases their erodibility, by binding the soil and improving permeability. Clear, well drained and well-graded gravel and gravel-sand mixes are typically the least erodible soils.

Vegetative cover protects the soil surface from raindrop impact, reduces runoff velocity, and has a root system that can greatly aid in keeping soil particles together. Vegetative cover is most crucial along steep slopes, stream banks, and erodible soils due to the higher erosion potential.

Topography affects both the volume and rate of runoff and is defined as the size, shape and slope of a watershed.

Erosion risks are further increased in climates that produce storms that are frequent and intense or are of long duration. Higher risk periods can change throughout the year coinciding with seasonal changes in temperature and variations in rainfall.

*Principles of Controlling Erosion and Sedimentation*

Environmental Site Design (ESD) is the process of using small scale stormwater management practices, non-structural techniques and site planning to mimic natural hydrologic runoff characteristics and minimize the impacts of land development on water resources. As further clarified in the Maryland Standards and Specifications for Soil Erosion and Sediment Control (Manual), ESD emphasizes conserving natural features, drainage patterns, and vegetation; minimizing impervious surfaces; slowing down runoff and increasing infiltration. These are all topics which the trail designer must incorporate into the project from its earliest stages.



The above Manual recommends the following 8 principles that should be followed in the development of the erosion and sediment control plans.

1. Plan the development to fit the site: The most effective way to prevent erosion from occurring on the trail project is to avoid modifying slopes. Trails should be oriented to follow existing grade as closely as possible.
2. Protect and avoid natural resources: Natural resources include wetlands, springheads, floodplains, and stream buffers. If avoidance is not feasible, efforts must be made to minimize impacts.
3. Protect and avoid steep slopes and highly erodible soils: Impacting steep slopes and/or highly erodible soils during trail construction may not always be possible. In these situations the trail designer must plan to control or divert upstream runoff and stabilize unprotected surface areas during trail construction.
4. Minimize disturbed areas: Regulations allow a single grading unit (20 acres) as the maximum contiguous area to be graded at one time. Work may not begin on the subsequent grading unit until at least 50% of the disturbed area of the previous grading unit has been stabilized. No more than 30 acres cumulatively may be disturbed at one time. Sequencing and phasing of the project should be utilized during the planning of all projects to address ahead of time.
5. Stabilize exposed soils as soon as practicable: Quickly stabilizing earth disturbance is a key to limiting erosion and sedimentation. All perimeter controls and slopes 3:1 and greater shall be stabilized within three calendar days while all other areas are required to be stabilized within seven calendar days.
6. Control and/or manage onsite and offsite runoff: Understanding the flows draining to, through and from the project site will help in the selection of erosion controls. Whenever possible, clear water from upstream should be diverted around the project disturbed areas.

7. Protect perimeter areas and maintain soils onsite: The project limit of disturbance must be clearly marked in the field. Perimeter controls are utilized to filter out sediment before runoff leaves the disturbed areas of the site.
8. Make provisions for inspecting and maintaining sediment controls: Trail plans should clearly identify the importance of inspecting and maintaining onsite erosion and sediment controls. The owner/developer should be prepared to inspect the controls on a weekly basis at a minimum or after every major rain event.

### *Erosion & Sediment Controls*

Erosion & Sediment Controls (aka BMPs) are designed to imitate and protect the natural functions of forests. These controls minimize the risk of sediment and other pollutants getting into waterbodies, maintain the natural flow of water in streams and wetlands, protects shoreland vegetation and provide a safe and stable trail system.

The Manual includes an abundance of approved sediment controls however not all of them will be necessary for trail projects. The following is a list of erosion and sediment controls that will be used on typical trail projects. The trail designer should ultimately refer to the Manual for proper selection and placement of each control selected for the project.

### *Stabilized Construction Entrance*

A stabilized construction entrance provides an entrance to and exit from the project site while limiting the amount of sediment that is transported onto roadways from construction equipment. It is constructed by placing a layer of aggregate, underlain with geotextile. Depending on the size and conditions of the project site it may be necessary to have more than one entrance/exit. It must be noted that a stabilized construction entrance will be required at each of the entrance/exit locations.

Additionally, any surface water (gutter flows, etc) directed to the stabilized construction entrance shall be piped underneath it. The pipe shall be sized at a minimum to safely convey the 2-year, 24-hour storm event. The minimum allowable pipe size shall be 6 inches.



The below construction detail has been taken from the Manual for reference:

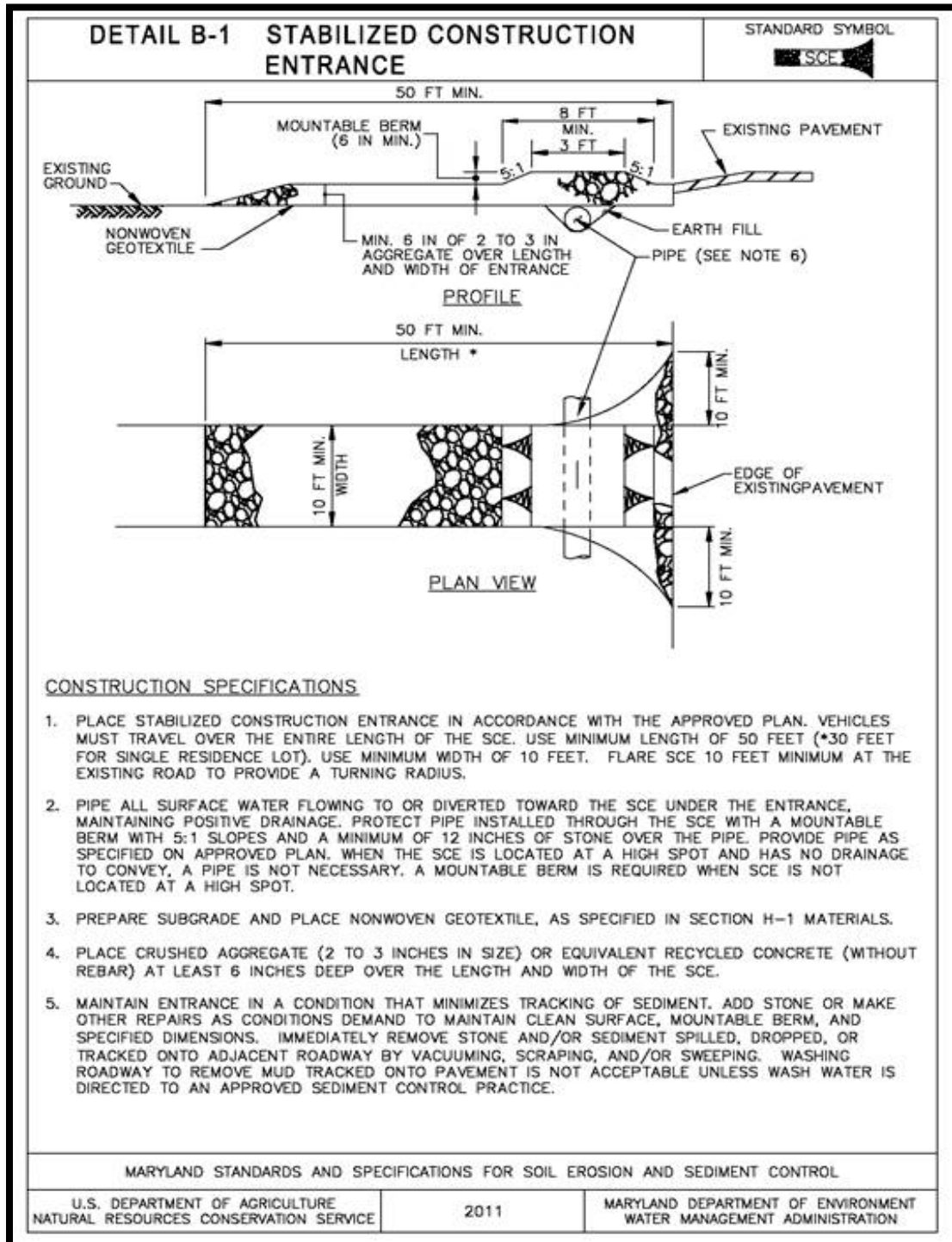

*Silt Fence*

Silt fence is a perimeter site control that will trap sediment from upslope sediment-laden runoff. The fence is intended to control sheet flow runoff as opposed to concentrated flows. It is simply installed by placing woven geotextile on contour, or downslope of the disturbed areas.

Its use is based on both slope length and steepness of the drainage area contributing to it. If the site falls outside of the maximum silt fence design constraints (shown below), there is an alternative Super Silt Fence with greater allowable maximum design constraints (see below). Super silt fence is a similar type perimeter barrier with the exception that the woven geotextile is installed over chain link fence for greater stability. Super silt fence is more desirable for protection of sensitive features like wetlands, streams, etc. In some cases where super silt fence is not allowable based on the slope lengths, alternative controls will need to be selected from the Manual (sediment traps, basins, etc.).



**Silt fence**



**Super Silt Fence**

These types of controls will lose effectiveness if they are allowed to become clogged with sediment, knocked over, etc. Periodic inspections are necessary to maintain their intended functionality.



The below construction details have been taken from the Manual for reference:

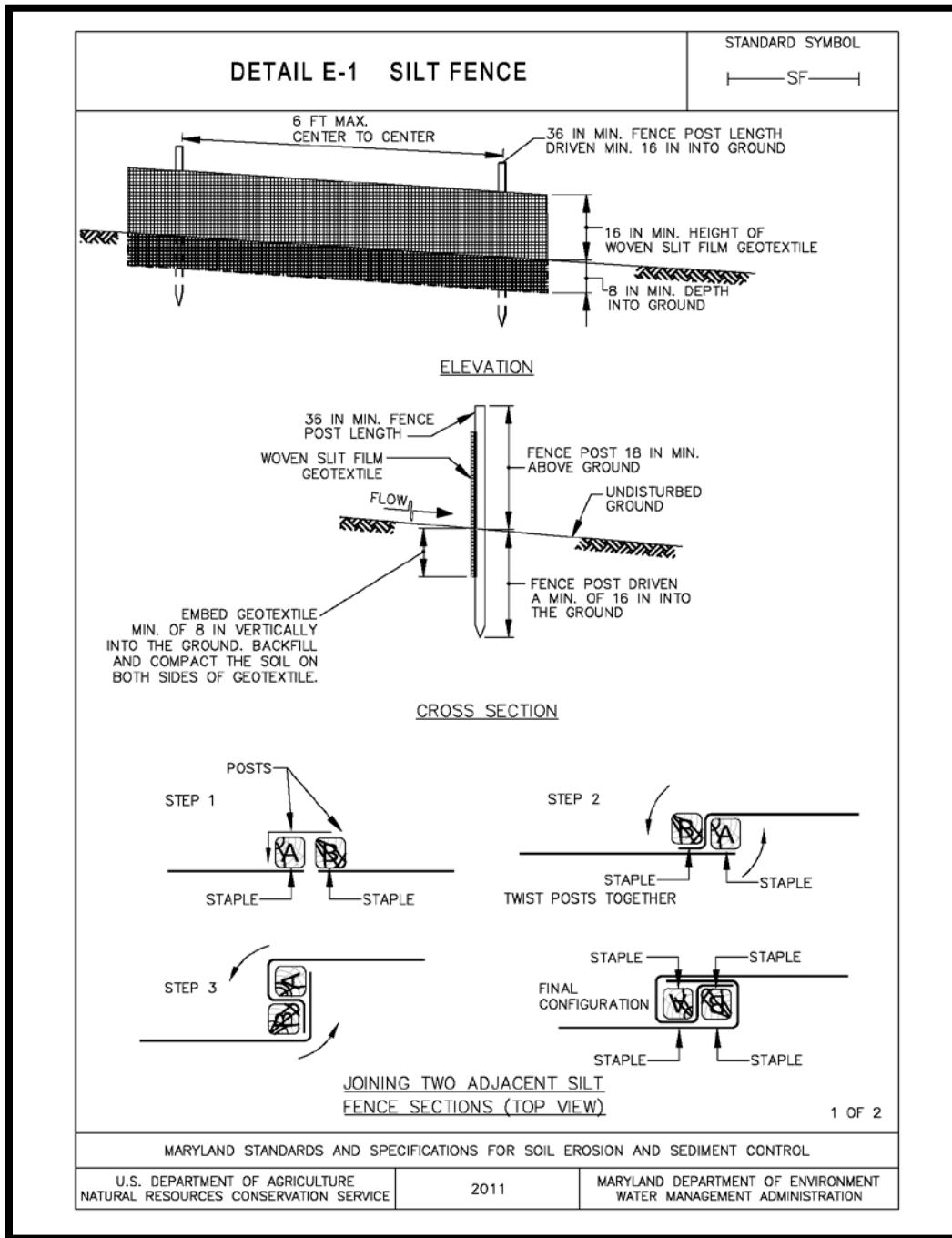

**Table E.1: Silt Fence Design Constraints**

Average Slope Steepness	Maximum Slope Length	Maximum Silt Fence Length
Flatter than 50:1 (<2%)	300 feet*	Unlimited
50:1 to 10:1 (2-10%)	125 feet	1,000 feet
<10:1 to 5:1 (>10-20%)	100 feet	750 feet
<5:1 (>20%)	40 feet	250 feet

\* Maximum slope length is unlimited on Hydrologic Soil Group (HSG) "A" soils.

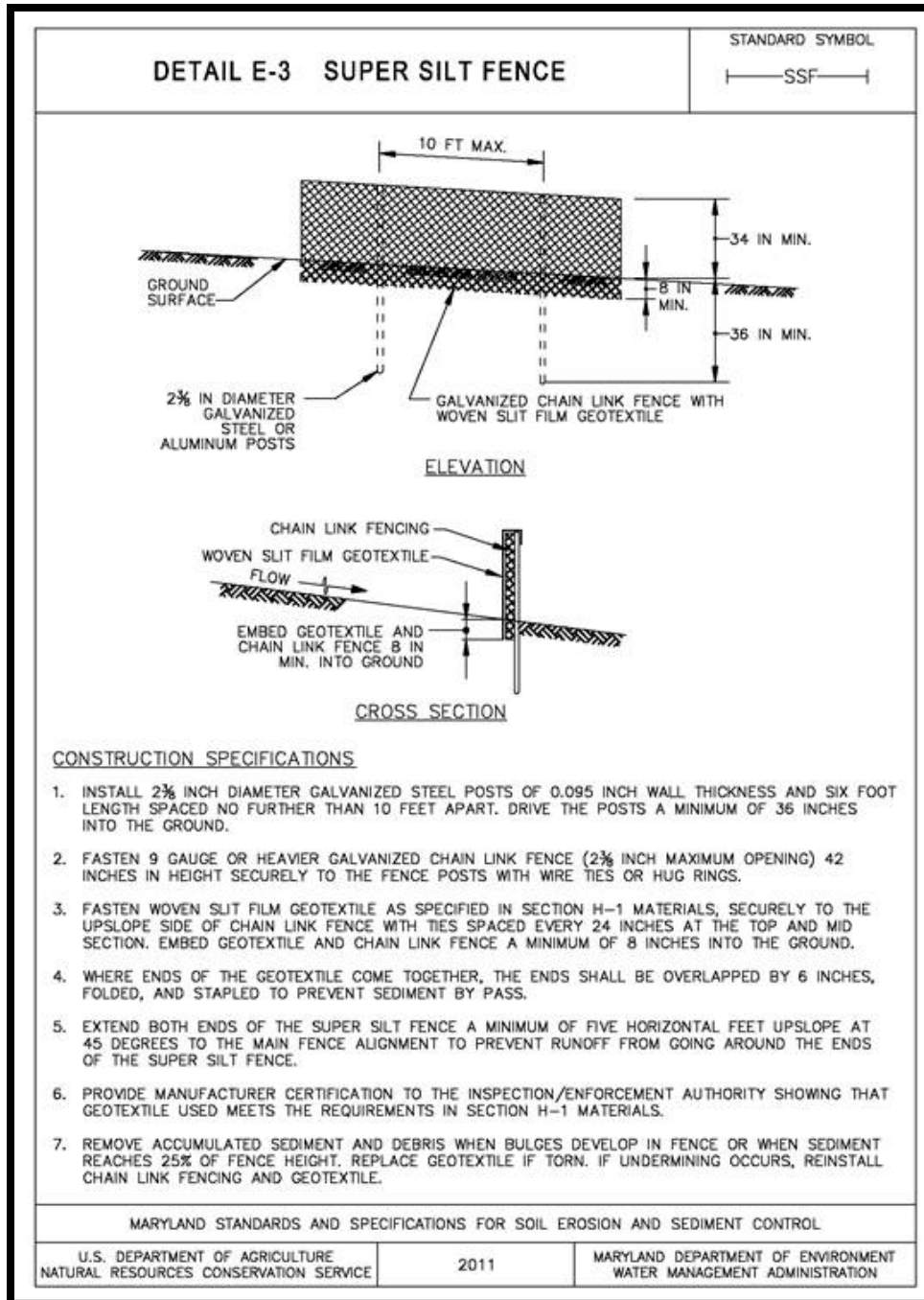

**Table E.3: Super Silt Fence Design Constraints**

Average Slope Steepness	Maximum Slope Length	Maximum Super Silt Fence Length
Flatter than 10:1 (0 - <10%)	Unlimited	Unlimited
10:1 to 5:1 (10 - 20%)	200 feet	1,500 feet
<5:1 to 3:1 (>20 - 33%)	150 feet	1,000 feet
<3:1 to 2:1 (>33 - 50%)	100 feet	500 feet
Steeper than 2:1 (>50%)	50 feet	250 feet

### Rock Outlet Protection

Keeping water off the trail tread is one of the top priorities of the trail designer. At times this may require the use of graded swales and/or culverts to convey runoff in differing directions. Once runoff (clean or sediment laden) is collected and conveyed by a channel or culvert it becomes what is referred to as a concentrated flow. Locations receiving concentrated flows tend to erode more often due to the increase in stormwater velocity. Rock lining can be installed at these proposed outfall locations to reduce the velocity of the discharge and control erosion.



There are three (3) types of rock outlet protection (ROP) details, ROP I, ROP II and ROP III (shown below) which are selected based on the outlet channel conditions. Once the type of ROP is selected the tailwater condition of the outlet must be determined. Typically, if the tailwater just below the outlet is less than half the pipe diameter the condition is classified as “minimum tailwater”. If the tailwater is more than half of the outlet diameter, a “maximum tailwater” condition should be assumed. Once the tailwater condition is selected, the riprap size and apron length can be determined utilizing the Design of Outlet Protection graphs (see Figure D.2 and D.3 below). The downstream width of the apron will be at a minimum equal to the outlet diameter + the apron length for minimum tailwater conditions; for maximum tailwater conditions the width will equal the outlet diameter + the apron length x 0.4. Lastly, the riprap must extend up the sides of the apron equal to the maximum depth of flow.

Table D.2: Riprap Sizes and Thickness

Class	$d_{60}$	$d_{100}$	Thickness (T)
Class I	9.5 inches	15 inches	19 inches
Class II	16 inches	24 inches	32 inches
Class III	23 inches	34 inches	46 inches

The below construction details have been taken from the Manual for reference:

<b>DETAIL D-4-1-A ROCK OUTLET PROTECTION I</b>		STANDARD SYMBOL <b>ROP1</b>
		DISCHARGE TO SEMI CONFINED CHANNEL SECTION
<p><b>CONSTRUCTION SPECIFICATIONS</b></p> <ol style="list-style-type: none"> <li>1. RIPRAP AND STONE MUST CONFORM TO THE SPECIFIED CLASS.</li> <li>2. USE NONWOVEN GEOTEXTILE AS SPECIFIED IN SECTION H-1 MATERIALS, AND PROTECT FROM PUNCTURING, CUTTING, OR TEARING. REPAIR ANY DAMAGE OTHER THAN AN OCCASIONAL SMALL HOLE BY PLACING ANOTHER PIECE OF GEOTEXTILE OVER THE DAMAGED PART OR BY COMPLETELY REPLACING THE GEOTEXTILE. PROVIDE A MINIMUM OF ONE FOOT OVERLAP FOR ALL REPAIRS AND FOR JOINING TWO PIECES OF GEOTEXTILE TOGETHER.</li> <li>3. PREPARE THE SUBGRADE FOR GEOTEXTILE OR STONE FILTER (3/8 TO 1 1/2 INCH STONE FOR 6 INCH MINIMUM DEPTH) AND RIPRAP TO THE REQUIRED LINES AND GRADES. COMPACT ANY FILL REQUIRED IN THE SUBGRADE TO A DENSITY OF APPROXIMATELY THAT OF THE SURROUNDING UNDISTURBED MATERIAL.</li> <li>4. EXTEND GEOTEXTILE AT LEAST 6 INCHES BEYOND EDGES OF RIPRAP AND EMBED AT LEAST 4 INCHES AT SIDES OF THE RIPRAP.</li> <li>5. CONSTRUCT RIPRAP OUTLET TO FULL COURSE THICKNESS IN ONE OPERATION AND IN SUCH A MANNER AS TO AVOID DISPLACEMENT OF UNDERLYING MATERIALS. PLACE STONE FOR RIPRAP OUTLET IN A MANNER THAT WILL ENSURE THAT IT IS REASONABLY HOMOGENOUS WITH THE SMALLER STONES AND SPALLS FILLING THE VOIDS BETWEEN THE LARGER STONES. PLACE RIPRAP IN A MANNER TO PREVENT DAMAGE TO THE STONE FILTER BLANKET OR GEOTEXTILE. HAND PLACE TO THE EXTENT NECESSARY.</li> <li>6. WHERE NO ENDWALL IS USED, CONSTRUCT THE UPSTREAM END OF THE APRON SO THAT THE WIDTH IS TWO TIMES THE DIAMETER OF THE OUTLET PIPE, AND EXTEND THE STONE UNDER THE OUTLET BY A MINIMUM OF 18 INCHES.</li> <li>7. CONSTRUCT APRON WITH 0% SLOPE ALONG ITS LENGTH AND WITHOUT OBSTRUCTIONS. PLACE STONE SO THAT IT BLENDS IN WITH EXISTING GROUND.</li> <li>8. MAINTAIN LINE, GRADE, AND CROSS SECTION. KEEP OUTLET FREE OF EROSION. REMOVE ACCUMULATED SEDIMENT AND DEBRIS. AFTER HIGH FLOWS INSPECT FOR SCOUR AND DISLODGED RIPRAP. MAKE NECESSARY REPAIRS IMMEDIATELY.</li> </ol>		
MARYLAND STANDARDS AND SPECIFICATIONS FOR SOIL EROSION AND SEDIMENT CONTROL		
U.S. DEPARTMENT OF AGRICULTURE NATURAL RESOURCES CONSERVATION SERVICE	2011	MARYLAND DEPARTMENT OF ENVIRONMENT WATER MANAGEMENT ADMINISTRATION

**DETAIL D-4-1-B ROCK OUTLET PROTECTION II**

STANDARD SYMBOL

ROPII

DISCHARGE TO CONFINED CHANNEL SECTION

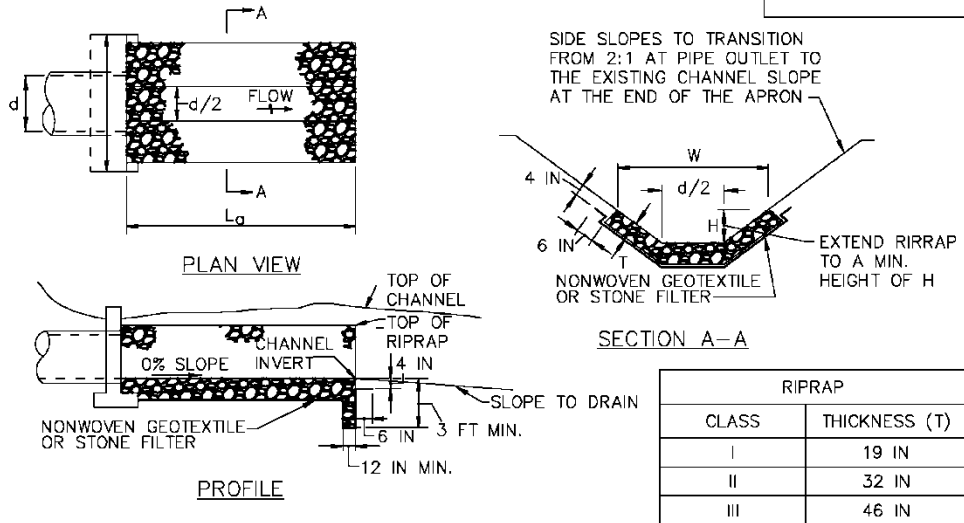

**CONSTRUCTION SPECIFICATIONS**

1. RIPRAP AND STONE MUST CONFORM TO THE SPECIFIED CLASS.
2. USE NONWOVEN GEOTEXTILE AS SPECIFIED IN SECTION H-1 MATERIALS, AND PROTECT FROM PUNCTURING, CUTTING, OR TEARING. REPAIR ANY DAMAGE OTHER THAN AN OCCASIONAL SMALL HOLE BY PLACING ANOTHER PIECE OF GEOTEXTILE OVER THE DAMAGED PART OR BY COMPLETELY REPLACING THE GEOTEXTILE. PROVIDE A MINIMUM OF ONE FOOT OVERLAP FOR ALL REPAIRS AND FOR JOINING TWO PIECES OF GEOTEXTILE TOGETHER.
3. PREPARE THE SUBGRADE FOR GEOTEXTILE OR STONE FILTER (3/8 TO 1 1/2 INCH STONE FOR 6 INCH MINIMUM DEPTH) AND RIPRAP TO THE REQUIRED LINES AND GRADES. COMPACT ANY FILL REQUIRED IN THE SUBGRADE TO A DENSITY OF APPROXIMATELY THAT OF THE SURROUNDING UNDISTURBED MATERIAL.
4. EXTEND GEOTEXTILE AT LEAST 6 INCHES BEYOND EDGES OF RIPRAP AND EMBED AT LEAST 4 INCHES AT SIDES OF RIPRAP.
5. CONSTRUCT RIPRAP OUTLET TO FULL COURSE THICKNESS IN ONE OPERATION AND IN SUCH A MANNER AS TO AVOID DISPLACEMENT OF UNDERLYING MATERIALS. PLACE STONE FOR RIPRAP OUTLET IN A MANNER THAT WILL ENSURE THAT IT IS REASONABLY HOMOGENOUS WITH THE SMALLER STONES AND SPALLS FILLING THE VOIDS BETWEEN THE LARGER STONES. PLACE RIPRAP IN A MANNER TO PREVENT DAMAGE TO THE STONE FILTER BLANKET OR GEOTEXTILE. HAND PLACE TO THE EXTENT NECESSARY.
6. WHERE NO ENDWALL IS USED, CONSTRUCT THE UPSTREAM END OF THE APRON SO THAT THE WIDTH IS TWO TIMES THE DIAMETER OF THE OUTLET PIPE, AND EXTEND THE STONE UNDER THE OUTLET BY A MINIMUM OF 18 INCHES.
7. CONSTRUCT APRON WITH 0% SLOPE ALONG ITS LENGTH AND WITHOUT OBSTRUCTIONS. PLACE STONE SO THAT IT BLENDS IN WITH EXISTING GROUND.
8. MAINTAIN LINE, GRADE, AND CROSS SECTION. KEEP OUTLET FREE OF EROSION. REMOVE ACCUMULATED SEDIMENT AND DEBRIS. AFTER HIGH FLOWS INSPECT FOR SCOUR AND DISLODGED RIPRAP. MAKE NECESSARY REPAIRS IMMEDIATELY.

MARYLAND STANDARDS AND SPECIFICATIONS FOR SOIL EROSION AND SEDIMENT CONTROL

U.S. DEPARTMENT OF AGRICULTURE  
NATURAL RESOURCES CONSERVATION SERVICE

2011

MARYLAND DEPARTMENT OF ENVIRONMENT  
WATER MANAGEMENT ADMINISTRATION

# DETAIL D-4-1-C ROCK OUTLET PROTECTION III

STANDARD SYMBOL

ROPIII

DISCHARGE TO AN UNCONFINED CHANNEL OR FLAT AREA

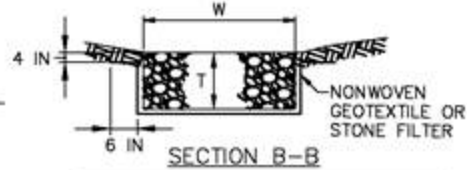
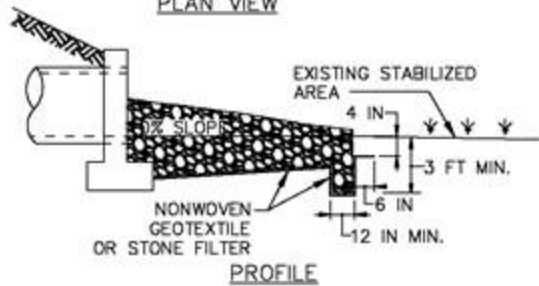
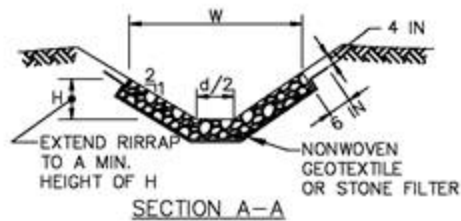
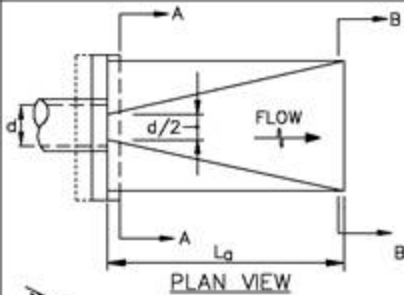

RIPRAP	
CLASS	THICKNESS (T)
I	19 IN
II	32 IN
III	46 IN

## CONSTRUCTION SPECIFICATIONS

1. RIPRAP AND STONE MUST CONFORM TO THE SPECIFIED CLASS.
2. USE NONWOVEN GEOTEXTILE, AS SPECIFIED IN SECTION H-1 MATERIALS, AND PROTECT FROM PUNCTURING, CUTTING, OR TEARING. REPAIR ANY DAMAGE OTHER THAN AN OCCASIONAL SMALL HOLE BY PLACING ANOTHER PIECE OF GEOTEXTILE OVER THE DAMAGED PART OR BY COMPLETELY REPLACING THE GEOTEXTILE. PROVIDE A MINIMUM OF ONE FOOT OVERLAP FOR ALL REPAIRS AND FOR JOINING TWO PIECES OF GEOTEXTILE TOGETHER.
3. PREPARE THE SUBGRADE FOR GEOTEXTILE OR STONE FILTER (¾ TO 1½ INCH MINIMUM STONE FOR 6 INCH MINIMUM DEPTH) AND RIPRAP TO THE REQUIRED LINES AND GRADES. COMPACT ANY FILL REQUIRED IN THE SUBGRADE TO A DENSITY OF APPROXIMATELY THAT OF THE SURROUNDING UNDISTURBED MATERIAL.
4. EXTEND GEOTEXTILE AT LEAST 6 INCHES BEYOND EDGES OF RIPRAP AND EMBED AT LEAST 4 INCHES AT SIDES OF RIPRAP.
5. CONSTRUCT RIPRAP OUTLET TO FULL COURSE THICKNESS IN ONE OPERATION AND IN SUCH A MANNER AS TO AVOID DISPLACEMENT OF UNDERLYING MATERIALS. PLACE STONE FOR RIPRAP OUTLET IN A MANNER THAT WILL ENSURE THAT IT IS REASONABLY HOMOGENOUS WITH THE SMALLER STONES AND SPALLS FILLING THE VOIDS BETWEEN THE LARGER STONES. PLACE RIPRAP IN A MANNER TO PREVENT DAMAGE TO THE FILTER BLANKET OR GEOTEXTILE. HAND PLACE TO THE EXTENT NECESSARY.
6. WHERE NO ENDWALL IS USED, CONSTRUCT THE UPSTREAM END OF THE APRON SO THAT THE WIDTH IS TWO TIMES THE DIAMETER OF THE OUTLET PIPE, AND EXTEND THE STONE UNDER THE OUTLET BY A MINIMUM OF 18 INCHES.
7. CONSTRUCT APRON WITH 0% SLOPE ALONG ITS LENGTH AND WITHOUT OBSTRUCTIONS. PLACE STONE SO THAT IT BLENDS IN WITH EXISTING GROUND.
8. MAINTAIN LINE, GRADE, AND CROSS SECTION. KEEP OUTLET FREE OF EROSION. REMOVE ACCUMULATED SEDIMENT AND DEBRIS. AFTER HIGH FLOWS INSPECT FOR SCOUR AND RIPRAP DISLOGGED RIPRAP. MAKE NECESSARY REPAIRS IMMEDIATELY.

MARYLAND STANDARDS AND SPECIFICATIONS FOR SOIL EROSION AND SEDIMENT CONTROL

U.S. DEPARTMENT OF AGRICULTURE  
NATURAL RESOURCES CONSERVATION SERVICE

2011

MARYLAND DEPARTMENT OF ENVIRONMENT  
WATER MANAGEMENT ADMINISTRATION

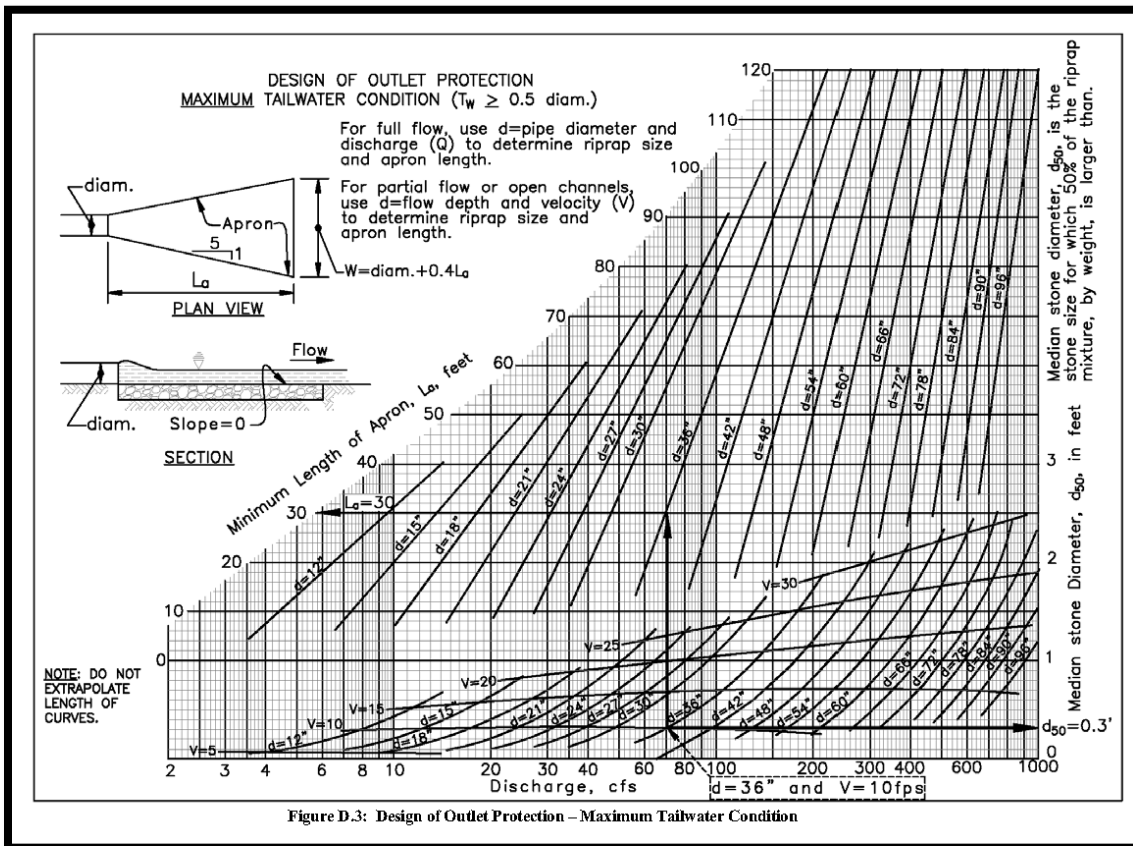
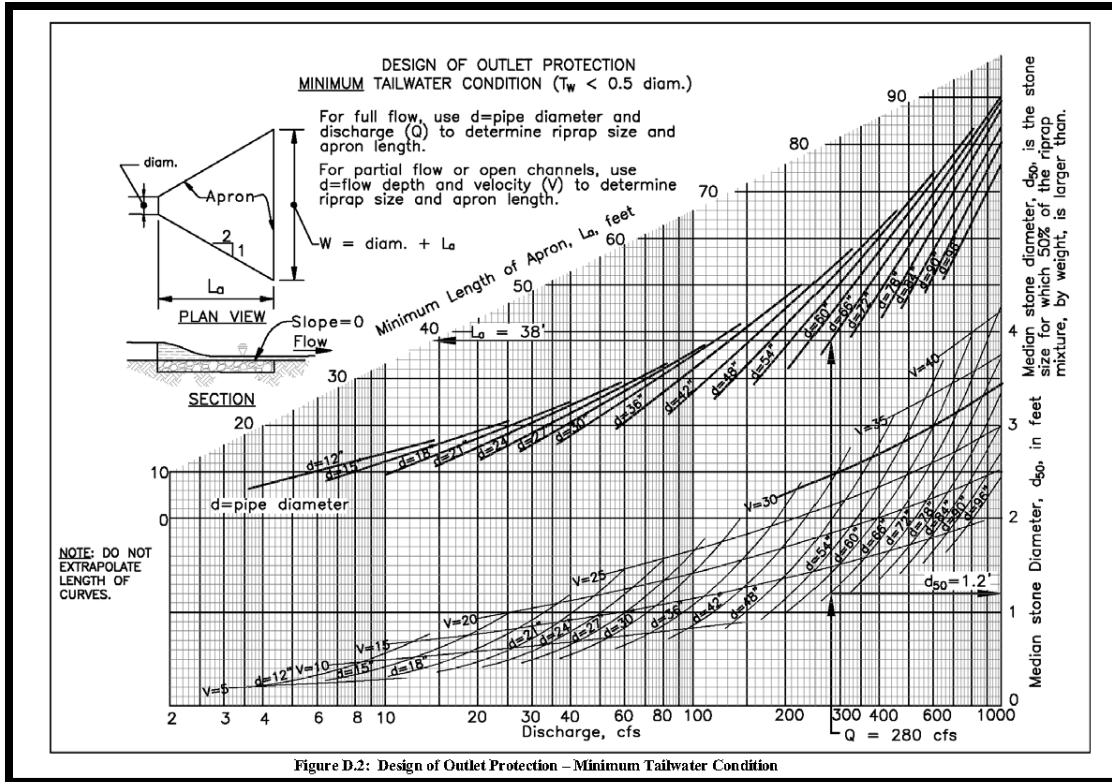

*Soil Stabilization Matting*

Soil stabilization matting is used to stabilize channels and steep slopes until a groundcover is established. As mentioned above, disturbed soils lacking vegetation, or lacking significant vegetative cover, are more susceptible to erosion and therefore need protection. Some steep slopes may require a permanent matting for more erosive velocities.

The matting must be designed withstand velocity and shear stress from the 2-year, 24-hour storm for temporary applications and 10-year, 24-hour storm for permanent applications. Temporary matting must be made with degradable fibers and have a maximum permissible velocity of six feet per second. Permanent matting is made with non-degradable fiber with open weave and has a maximum permissible velocity of eight and one half feet per second.



The following construction detail has been taken from the Manual for reference:



**DETAIL B-4-6-B TEMPORARY SOIL STABILIZATION MATTING SLOPE APPLICATION**

STANDARD SYMBOL

TSSMS - \* lb/ft<sup>2</sup>  
(\* INCLUDE SHEAR STRESS)

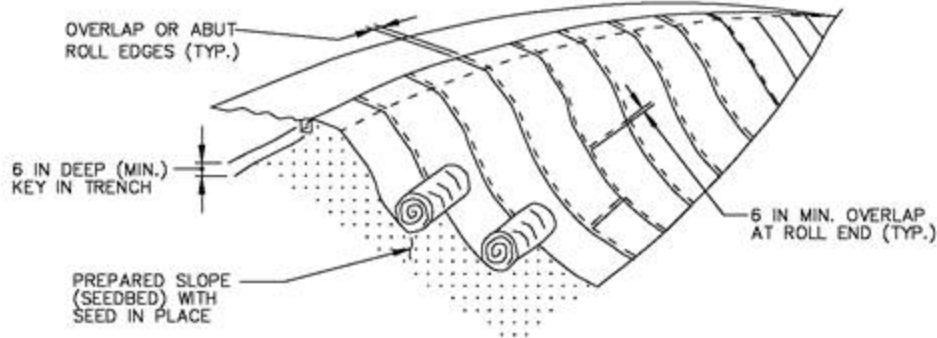

ISOMETRIC VIEW

CONSTRUCTION SPECIFICATIONS

1. USE MATTING THAT HAS A DESIGN VALUE FOR SHEAR STRESS EQUAL TO OR HIGHER THAN THE SHEAR STRESS DESIGNATED ON APPROVED PLANS.
2. USE TEMPORARY SOIL STABILIZATION MATTING MADE OF DEGRADABLE (LASTS 6 MONTHS MINIMUM) NATURAL OR MAN-MADE FIBERS (MOSTLY ORGANIC). MAT MUST HAVE UNIFORM THICKNESS AND DISTRIBUTION OF FIBERS THROUGHOUT AND BE SMOLDER RESISTANT. CHEMICALS USED IN THE MAT MUST BE NON-LEACHING AND NON-TOXIC TO VEGETATION AND SEED GERMINATION AND NON-INJURIOUS TO THE SKIN. IF PRESENT, NETTING MUST BE EXTRUDED PLASTIC WITH A MAXIMUM MESH OPENING OF 2x2 INCHES AND SUFFICIENTLY BONDED OR SEWN ON 2 INCH CENTERS ALONG LONGITUDINAL AXIS OF THE MATERIAL TO PREVENT SEPARATION OF THE NET FROM THE PARENT MATERIAL.
3. SECURE MATTING USING STEEL STAPLES, WOOD STAKES, OR BIODEGRADABLE EQUIVALENT. STAPLES MUST BE "U" OR "T" SHAPED STEEL WIRE HAVING A MINIMUM GAUGE OF NO. 11 AND NO. 8 RESPECTIVELY. "U" SHAPED STAPLES MUST AVERAGE 1 TO 1½ INCHES WIDE AND BE A MINIMUM OF 6 INCHES LONG. "T" SHAPED STAPLES MUST HAVE A MINIMUM 8 INCH MAIN LEG, A MINIMUM 1 INCH SECONDARY LEG, AND A MINIMUM 4 INCH HEAD. WOOD STAKES MUST BE ROUGH-SAWN HARDWOOD, 12 TO 24 INCHES IN LENGTH, 1x3 INCH IN CROSS SECTION, AND WEDGE SHAPED AT THE BOTTOM.
4. PERFORM FINAL GRADING, TOPSOIL APPLICATION, SEEDBED PREPARATION, AND PERMANENT SEEDING IN ACCORDANCE WITH SPECIFICATIONS. PLACE MATTING WITHIN 48 HOURS OF COMPLETING SEEDING OPERATIONS UNLESS END OF WORKDAY STABILIZATION IS SPECIFIED ON THE APPROVED EROSION & SEDIMENT CONTROL PLAN.
5. UNROLL MATTING DOWNSLOPE. LAY MAT SMOOTHLY AND FIRMLY UPON THE SEEDED SURFACE. AVOID STRETCHING THE MATTING.
6. OVERLAP OR ABUT ROLL EDGES PER MANUFACTURER RECOMMENDATIONS. OVERLAP ROLL ENDS BY 6 INCHES (MINIMUM), WITH THE UPSLOPE MAT OVERLAPPING ON TOP OF THE DOWNSLOPE MAT.
7. KEY IN THE UPSLOPE END OF MAT 6 INCHES (MINIMUM) BY DIGGING A TRENCH, PLACING THE MATTING ROLL END IN THE TRENCH, STAPLING THE MAT IN PLACE, REPLACING THE EXCAVATED MATERIAL, AND TAMPING TO SECURE THE MAT END IN THE KEY.
8. STAPLE/STAKE MAT IN A STAGGERED PATTERN ON 4 FOOT (MAXIMUM) CENTERS THROUGHOUT AND 2 FOOT (MAXIMUM) CENTERS ALONG SEAMS, JOINTS, AND ROLL ENDS.
9. ESTABLISH AND MAINTAIN VEGETATION SO THAT REQUIREMENTS FOR ADEQUATE VEGETATIVE ESTABLISHMENT ARE CONTINUOUSLY MET IN ACCORDANCE WITH SECTION B-4 VEGETATIVE STABILIZATION.

MARYLAND STANDARDS AND SPECIFICATIONS FOR SOIL EROSION AND SEDIMENT CONTROL

U.S. DEPARTMENT OF AGRICULTURE  
NATURAL RESOURCES CONSERVATION SERVICE

2011

MARYLAND DEPARTMENT OF ENVIRONMENT  
WATER MANAGEMENT ADMINISTRATION

**DETAIL B-4-6-A**

**TEMPORARY SOIL STABILIZATION MATTING CHANNEL APPLICATION**

STANDARD SYMBOL

TSSMC - \* lb/ft<sup>2</sup>  
(\* INCLUDE SHEAR STRESS)

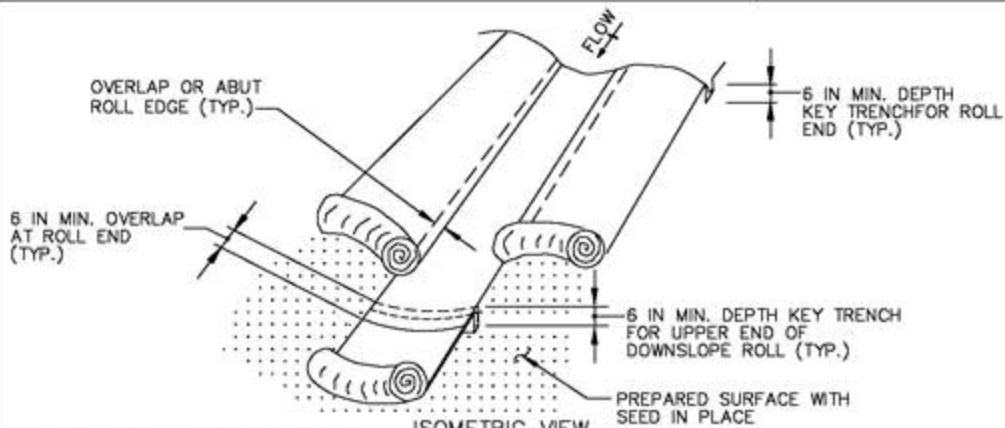

**CONSTRUCTION SPECIFICATIONS**      ISOMETRIC VIEW

1. USE MATTING THAT HAS A DESIGN VALUE FOR SHEAR STRESS EQUAL TO OR HIGHER THAN THE SHEAR STRESS DESIGNATED ON APPROVED PLANS.
2. USE TEMPORARY SOIL STABILIZATION MATTING MADE OF DEGRADABLE (LASTS 6 MONTHS MINIMUM) NATURAL OR MAN-MADE FIBERS (MOSTLY ORGANIC). MAT MUST HAVE UNIFORM THICKNESS AND DISTRIBUTION OF FIBERS THROUGHOUT AND BE SMOLDER RESISTANT. CHEMICALS USED IN THE MAT MUST BE NON-LEACHING AND NON-TOXIC TO VEGETATION AND SEED GERMINATION AND NON-INJURIOUS TO THE SKIN. IF PRESENT, NETTING MUST BE EXTRUDED PLASTIC WITH A MAXIMUM MESH OPENING OF 2x2 INCHES AND SUFFICIENTLY BONDED OR SEWN ON 2 INCH CENTERS ALONG LONGITUDINAL AXIS OF THE MATERIAL TO PREVENT SEPARATION OF THE NET FROM THE PARENT MATERIAL.
3. SECURE MATTING USING STEEL STAPLES, WOOD STAKES, OR BIODEGRADABLE EQUIVALENT. STAPLES MUST BE "U" OR "T" SHAPED STEEL WIRE HAVING A MINIMUM GAUGE OF NO. 11 AND NO. 8 RESPECTIVELY. "U" SHAPED STAPLES MUST AVERAGE 1 TO 1½ INCHES WIDE AND BE A MINIMUM OF 6 INCHES LONG. "T" SHAPED STAPLES MUST HAVE A MINIMUM 8 INCH MAIN LEG, A MINIMUM 1 INCH SECONDARY LEG, AND A MINIMUM 4 INCH HEAD. WOOD STAKES MUST BE ROUGH-SAWN HARDWOOD, 12 TO 24 INCHES IN LENGTH, 1x3 INCH IN CROSS SECTION, AND WEDGE SHAPED AT THE BOTTOM.
4. PERFORM FINAL GRADING, TOPSOIL APPLICATION, SEEDBED PREPARATION, AND PERMANENT SEEDING IN ACCORDANCE WITH SPECIFICATIONS. PLACE MATTING WITHIN 48 HOURS OF COMPLETING SEEDING OPERATIONS UNLESS END OF WORKDAY STABILIZATION IS SPECIFIED ON THE APPROVED EROSION AND SEDIMENT CONTROL PLAN.
5. UNROLL MATTING IN DIRECTION OF WATER FLOW, CENTERING THE FIRST ROLL ON THE CHANNEL CENTERLINE. WORK FROM CENTER OF CHANNEL OUTWARD WHEN PLACING ROLLS. LAY MAT SMOOTHLY AND FIRMLY ON THE SEEDED SURFACE. AVOID STRETCHING THE MATTING.
6. KEY-IN UPSTREAM END OF EACH MAT ROLL BY DIGGING A 6 INCH (MINIMUM) TRENCH AT THE UPSTREAM END OF THE MATTING, PLACING THE ROLL END IN THE TRENCH, STAPLING THE MAT IN PLACE, REPLACING THE EXCAVATED MATERIAL, AND TAMPING TO SECURE THE MAT END.
7. OVERLAP OR ABUT THE ROLL EDGES PER MANUFACTURER RECOMMENDATIONS. OVERLAP ROLL ENDS BY 6 INCHES (MINIMUM), WITH THE UPSTREAM MAT OVERLAPPING ON TOP OF THE NEXT DOWNSTREAM MAT.
8. STAPLE/STAKE MAT IN A STAGGERED PATTERN ON 4 FOOT (MAXIMUM) CENTERS THROUGHOUT AND 2 FOOT (MAXIMUM) CENTERS ALONG SEAMS, JOINTS, AND ROLL ENDS.
9. ESTABLISH AND MAINTAIN VEGETATION SO THAT REQUIREMENTS FOR ADEQUATE VEGETATIVE ESTABLISHMENT ARE CONTINUOUSLY MET IN ACCORDANCE WITH SECTION B-4 VEGETATIVE STABILIZATION.

MARYLAND STANDARDS AND SPECIFICATIONS FOR SOIL EROSION AND SEDIMENT CONTROL

U.S. DEPARTMENT OF AGRICULTURE  
NATURAL RESOURCES CONSERVATION SERVICE

2011

MARYLAND DEPARTMENT OF ENVIRONMENT  
WATER MANAGEMENT ADMINISTRATION

### Stormwater Management

Constructing impervious (crushed aggregate, asphalt, etc) walking trails through existing forests, meadow fields and other pervious land cover will result in an increase of stormwater runoff. This increased stormwater must be managed with either structural or non-structural Best Management Practices (BMPs).

When designing the trail, elevated bridges and boardwalks may be desirable for wetland and stream locations. There are additional costs associated with constructing these structures as opposed to traditional crushed aggregate walking trails, however these structures can be considered pervious and of no disturbance to the existing site and therefore reduce the amount of required stormwater management. For most typical crushed aggregate walking trails, the non-structural Disconnection of Non Rooftop Runoff BMP (see below detail) may be selected to properly address stormwater management.

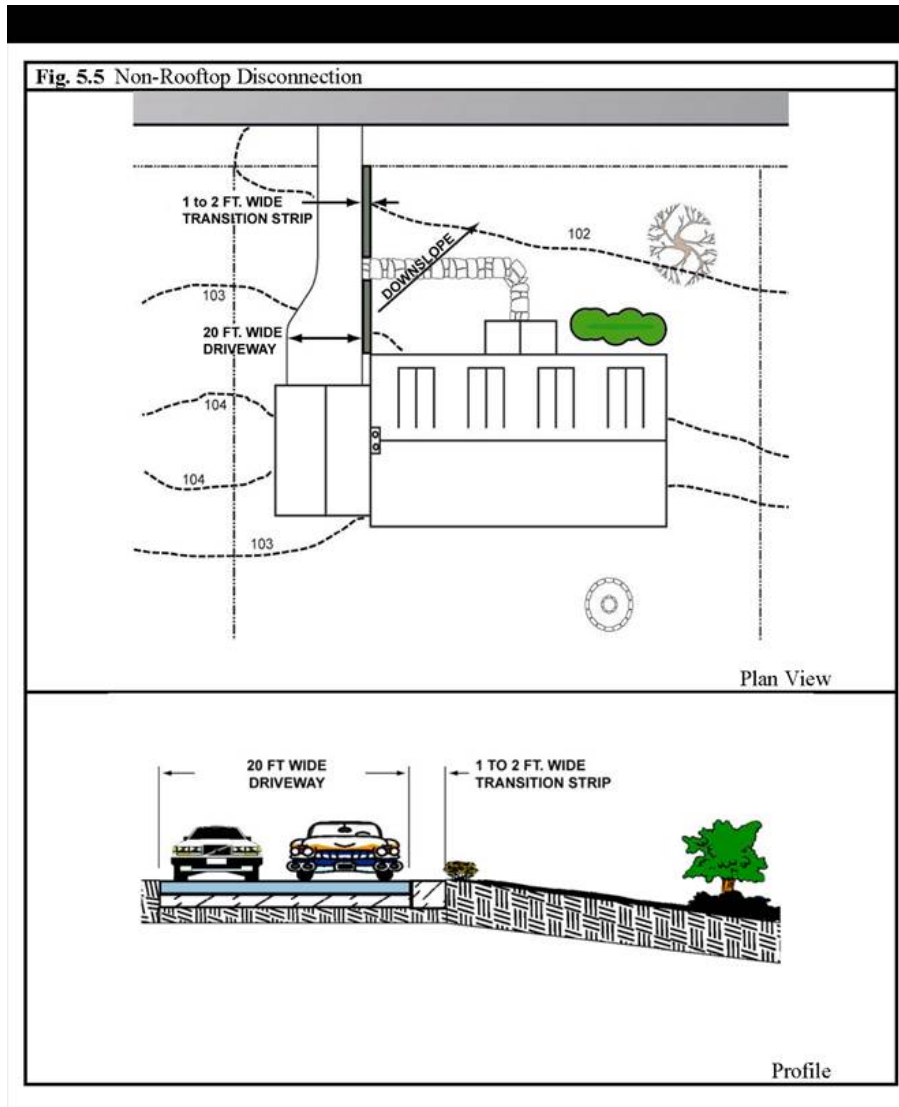

Stormwater calculations must be completed in accordance with the 2000 Maryland Stormwater Design Manual, 2007 Stormwater Management Act (Environmental Site Design), MDE design computations July 2010 and Howard County requirements. Additionally, there are fourteen performance standards (*Section 1.2 – General Performance Standards for Stormwater Management in Maryland of the 2000 Maryland Stormwater Design Manual Volumes I & II, see below*) that need to be addressed with each project. With

most typical trail projects, several of these standards may not be applicable. All calculations and standards should be provided in a stormwater management narrative and submitted to the County.

1. Standard No. 1 – Site designs shall minimize the generation of stormwater and maximize the pervious areas for stormwater treatment.
2. Standard No. 2 – Stormwater runoff generated from the development and discharged directly into a jurisdictional wetland or waters of the State of Maryland shall be adequately treated.
3. Standard No. 3 – Annual groundwater recharge rates shall be maintained by promoting infiltration through the use of structural and non-structural methods. At a minimum, the annual recharge from post development site conditions shall mimic the annual recharge from the pre development site conditions.
4. Standard No. 4 – Water quality management shall be provided through the use of environmental site design practices.
5. Standard No. 5 – Structural BMPs used for new development shall be designed to remove 80% of the average annual post development total suspended solids load (TSS) and 40% of the average annual post development total phosphorous load (TP). It is presumed that a BMP complies with this performance standard if it is: sized to capture the prescribed water quality volume (WQv), designed according to the specific performance criteria outlined in this manual, constructed properly and maintained regularly.
6. Standard No. 6 – Control of the 2-Year and 10-Year frequency storm events is required if the local authority determines that additional stormwater management is necessary because historical flooding problems exist and downstream floodplain development and conveyance system design cannot be controlled. In addition, safe conveyance of the 100-year storm event through stormwater management practices shall be provided.
7. Standard No. 7 – To protect stream channels from degradation, the channel protection storage volume (Cpv) shall be based on runoff from the one-year frequency storm event. Environmental site design practices shall be used to the maximum extent practicable to address Cpv. Any remaining Cpv requirements shall be addressed using stormwater practices described in Chapter 3.
8. Standard No. 8 – Stormwater discharges to critical areas with sensitive resources [e.g., cold water fisheries, shellfish beds, swimming beaches, recharge areas, water supply reservoirs, Chesapeake and Atlantic Coastal Bays Critical Area (see Appendix D.40)] may be subject to additional performance criteria.
9. Standard No. 9 – All stormwater management practices shall have an enforceable operation and maintenance agreement to ensure the system functions as designated.
10. Standard No. 10 – Every BMP shall have an acceptable form of water quality pretreatment.
11. Standard No. 11 – Redevelopment, defined as any construction, alteration or improvement on sites where existing land use is commercial, industrial, institutional or multi-family residential and site impervious exceeds 40%, is governed by special stormwater sizing criteria depending on the amount of increase or decrease in impervious area created by development.

12. Standard No. 12 – Certain industrial sites are required to prepare and implement a stormwater pollution prevention plan and file a notice of intent (NOI) under the provisions of Maryland’s Stormwater Industrial National Pollutant Discharge Elimination System (NPDES) general permit (a list of industrial categories subject to the pollution prevention requirement can be found in Appendix D.6). The requirements for preparing and implementing a stormwater pollution prevention plan are described in the general discharge permit available from MDE and guidance can be found in the United States Environmental Protection Agency’s (EPA) document entitled, “Storm Water Management for Industrial Activities, Developing Pollution Prevention Plans and Best Management Practices” (1992). The stormwater pollution prevention plan requirement applies to both existing and new industrial sites.
  
13. Standard No. 13 – Stormwater discharges from land uses or activities with higher potential for pollutant loadings, defined as hotspots in Chapter 2, may require the use of specific structural BMPs and pollution prevention practices. In addition, stormwater from a hotspot land use may not be infiltrated without proper pretreatment.
  
14. Standard No. 14 – In Maryland, local governments are usually responsible for most stormwater management review authority. Therefore, prior to design, applicants should always consult with their local reviewing agency to determine if they are subject to additional stormwater design requirements. In addition, certain earth disturbances may require NPDES construction general permit coverage from MDE (see Appendix D.7.)

*Submission and Review*

As the scope of trail projects will typically be consistent with one another, there will always be varying site constraints related to each project location. The trail designer should strive to prepare a plan consistent with the County’s rules and regulations. A concept plan should be prepared that clearly identifies the proposed trail location(s), mapping the proposed trail location, mapping, natural resources, and the ESD targets. This concept plan will be submitted to the County for review and further direction with how to proceed.

In addition to the County, the prepared concept plan will need to be approved by Howard Soil Conservation District as well. Most trail projects may comply with the limitations of the Standard Erosion and Sediment Control Plan (Standard Plan) due to the limited impacts to existing features. The Standard Plan waives many of the requirements of a traditional environmental concept plan. For trail projects, the District may allow some exceptions with the required Standard Plans limitations. It is highly recommended to contact Howard Soil Conservation District to discuss project details prior to any submissions.



**Utilities, Rights-of-Way, Easements, and Setback Requirements**

*Introduction*

During planning and construction, protection of utilities, establishing or identifying easements for utilities, grading, road rights-of-way, and setbacks are imperative to ensure final trail design location will conform to the Miss Utility Law and Howard County Zoning and Land Development Ordinances.

The Miss Utility Law provides a “one-call” notification to public utility / facility owners to identify and locate their specific utility, on and adjacent to the site location. This “one call” can be done by calling 811 or 1-800-257-7777 or via the Miss Utility website: [www.missutility.net](http://www.missutility.net).

The “one call” should be conducted during the design phase to identify any potential conflicts that may arise and at least two full business days prior to construction. If the project construction will be performed by multiple contractors, each contractor shall be required to prepare a “one call”.

The public utility will be marked within the location identified, with the applicable marking. The extent of the work should be marked in white, prior to requesting the “one call”. Any public utility within the work area will be identified with the following marking color:



Upon confirmation of mark-out for any existing utility, design of trail shall take into consideration applicable soil coverage and separation distances required for each utility. Any location where the proposed trail may cross a shallow utility, consideration shall be made to put the trail in a fill condition or adjust the trail to clear the utility location. The design team should contact the facility owner to determine specific separation and coverage requirements for that utility.

### **Design and Development Procedures**

Upon establishing a site for trail development, the Zoning Classification and Land Development Ordinances of the site shall be identified to establish approved uses, minimum site lot size requirements if applicable, and required setbacks from easements or established right-of-way. In addition, the property deed should be reviewed for any existing easements or public utility rights-of way.

The Zoning Regulations will identify, by Zoning District, the approved uses for the site and the required setbacks from street right-of-way and lot lines, which vary depending on the Zoning District. Once the appropriate Zoning District has been established, the design team may access the Howard County Zoning Regulations and determine required setbacks via the following link:

[https://www.municode.com/library/md/howard\\_county/codes/zoning?nodeId=HOWARD\\_CO\\_ZONING\\_REGULATIONS\\_S101.0RUCO](https://www.municode.com/library/md/howard_county/codes/zoning?nodeId=HOWARD_CO_ZONING_REGULATIONS_S101.0RUCO)

The Subdivision and Land Development Ordinances will provide information on construction setbacks in relationship to natural features, including wetlands, streams, steep slopes, and preservation of natural cover. It also provides dimensional requirements for access easements for vehicular traffic if applicable. The design team may access the Howard County Subdivision and Land Development Regulations via the following link:

[https://www.municode.com/library/md/howard\\_county/codes/code\\_of\\_ordinances?nodeId=HOCOCO\\_T16PLZOSULADERE\\_SUBTITLE\\_1SULADERE](https://www.municode.com/library/md/howard_county/codes/code_of_ordinances?nodeId=HOCOCO_T16PLZOSULADERE_SUBTITLE_1SULADERE)

### **Trail Planning and Management Fundamentals**

The fundamental components of contemporary, sustainable trail planning and management are referred to as Trail Management Objectives. Often referred to as “TMOs”, Trail Management Objectives should be established for every trail or shared-use path, as opposed to one TMO for an entire system of trails. Trails and shared-use paths may share same or similar design parameters, but that decision should be based upon how each of the paths-of-travel, and their associated corridors, will be intentionally Managed and then Designed to be utilized in that way.

Howard County DRP recommends that land managers establish trail management objectives during the trail planning process. Howard County DPR, DPZ and DLD need to determine if these will be required in code, or, simply Best Management Practices. TMOs establish the trail *standards and practices*, against which each trail’s assessed condition, indicating maintenance, budget, materials and manpower can be measured and performed. The TMOs, with their inherit Design Parameters, provide department staff, park manager, local park staff and community volunteers with the key tools they need to confidently manage and maintain a trail without having to second-guess design and maintenance choices. These TMOs help ensure a management framework of continuity and consistency over time and through personnel changes.

The following page contains an example of TMOs for a trail identified for potential future development. This example provides details that would then be implemented within a future planning and design process. It is important that these objectives be clearly determined prior to any formal planning process, as they provide intentional guidance as to what the design and construction of a new, or altered, trail will be.

Example: Trail Management Objectives detail for a specific trail

TRAIL CORRIDOR #1 – JUMPERS HILL – HIKING-ONLY TRAIL WITH BOARDWALK & BRIDGE				
Designed Use HIKER/PEDESTRIAN		Trail Class 3	Trail Class 4	Trail Class 5
Design Tread Width	Singe Lane	36"	48"	60"
	Double Lane	48"	60"	72"
	Structures (Minimum Width)	36"	48"	60"
Design Surface <sup>3</sup>	Type	<ul style="list-style-type: none"> <li>Native with some onsite borrow or imported material where needed for stabilization, occasional grading</li> <li>Intermittently rough</li> </ul>	<ul style="list-style-type: none"> <li>Native with improved sections of borrow or imported material, routine grading</li> <li>Minor roughness</li> </ul>	<ul style="list-style-type: none"> <li>Likely imported material, routine grading</li> <li>Uniform, firm, and stable</li> </ul>
	Protrusions	≤ 3" May be common, not continuous	≤ 2 " Uncommon, not continuous	No protrusions
	Obstacles (Maximum Height)	8"	6"	No obstacles
Design Grade <sup>3</sup>	Target Grade	3% – 12%	3% – 8%	1% – 5%
	Short Pitch Maximum	15%	10%	8% Universal Access BMPs = 5% – 8.33%
	Maximum Pitch Density	10% of the trail	10% of the trail	0% – 5% of the trail
Design Cross Slope	Target Cross Slope	5% – 7%	3% – 5%	2% – 3% (or crowned)
	Maximum Cross Slope	7%	5%	3%
Design Clearing	Height	8'	8'	10'
	Width	36" – 60"	48" – 72"	96"
	Shoulder Clearance	12"	12"	12"
Design Turn	Radius	4' – 8'	4' – 8'	6' – 12'



The five Trail Management Objectives consist of the following;

- A. Trail Type
- B. Trail Class
- C. Managed Use
- D. Designed Use
- E. Design Parameters

- A. Trail Type is a *fundamental trail category that indicates the predominant trail surface or trail foundation, and the general mode of travel the trail accommodates*. The Trail Type differentiates between the three basic kinds of trails: Standard/Terra, Snow, or Water. Unless stated otherwise, all Howard County trails, managed by the Department of Recreation and Parks (“DRP”), are Terra trails.
- B. Trail Class is the *prescribed scale of trail development, representing the intended design and management standards of the trail*. These are based upon the recognized Federal Trail Data Standards and National Trail Management Classes, both of which are in this Appendix to this report. Assign the most appropriate Trail Class for the trail or trail segment. If more than one Trail Class is assigned to the trail, identify each Trail Class by individual trail segment. Trail Classes for DRP are either Class 3, 4 or 5.
- C. Managed Use is determined by *the modes of travel that are actively managed and appropriate, considering the design and management of the trail*. Managed Use indicates a DRP management decision or intent to accommodate and/or encourage a specified type of trail use. Accommodating the Managed Use frequently determines use-specific trail maintenance and signage costs. There may be more than one Managed Use per trail or trail segment. Managed Use decisions should be documented, indicating the dates during which that use is actively managed. If there is more than one season of use, for a particular Managed Use, that should be noted in that trail’s TMOs as well.
  - 1. **Managed Season of Use:** The Managed Season of Use specifically defines the period of the time that the trail is available and managed in a safe and sustainable condition for the defined user.

*Example:* A Hiking trail, that is also managed to provide Universal Access, may not be universally accessible after a snowfall. Therefore, DRP might decide that for that particular trail, specific winter months are outside of the Managed Season of Use, unless the land manager determined to provide snow removal as part of the managed trail maintenance. However, during the identified Managed Season of Use, the land manager maintains the accessible tread in a safe and functional condition, such as removing tree limbs and other debris.
  - 2. **Prohibited Use:** Any mode of travel prohibited by the land manager. Any use that is prohibited by an official prohibition or closure order should be well documented and filed. Document the dates during which the use is prohibited. Cite the specific rules, regulations or standards for the prohibited use(s) and make them readily available to users before they arrive on site (via web) and site signage.
- D. Designed Use is the *intended use that controls the desired geometric design of the trail, and determines the subsequent maintenance parameters for the trail*. The Designed Use must be

identified for each trail or trail segment. The Designed Use identifies the single use or limiting factor that drives technical Design Parameters for the trail (i.e. tread width, grade, turning radius, etc.). The Designed Use is necessary to establish the trail’s geometric design standards from which the trail is designed, constructed, managed and maintained. While several Managed Uses may occur on the trail, there is only one Designed Use for any given trail or trail segment. Generally speaking, Designed Use for Howard County DRP trails are either Hiking, Biking, or Equestrian.

- E. Design Parameters are the *technical specifications for trail construction and maintenance, based on the Designed Use and Trail Class*. Design Parameters identify the technical specifications that drive the trail design, construction, maintenance, and subsequent reconstruction. For each combination of Designed Use and Trail Class, there should be a corresponding set of established Design Parameters. As a baseline, Penn Trails uses the established Federal Trail Data Standards, utilized by federal land management agencies, as the basis for determining specific Design Parameters for a trail or trail segment. In addition, trail designs must include additional field verified and sited criteria that are very site-specific and require sound trail design and engineering judgment to define parameters for each trail. Each Design Parameter for a specific trail should be identified as a specific value appropriate for the Benson Branch PTCs and trails.

*Example:* The recommended trail design parameter, for trail width, aligned within the proposed Jumpers Hill trail corridor, is 60”. This is shown in that trail corridor’s proposed TMOs as a specific width, and not a range, such as 36” to 60”. Every trail should have an assigned, specific value for each Design Parameter variable. Design Parameters, as part of the overall TMOs, should convey the dominant criteria that must define the geometric shape of a particular trail.

Together, these five Best Management Practices help planners objectively site trails in the appropriate areas with the most sustainable use and design parameters determined, thereby delivering better performance and sustainability, more trail user satisfaction, and less maintenance over the long term.

**TMOs RESULT IN THIS ASSET**



*VERSUS*

**THIS PROBLEM**



It should be noted that the U.S. Access Board Outdoor Guidelines do not prescribe different levels of accessibility. A trail is either accessible or it is not. Trails that meet the U.S. Access Board's Outdoor Developed Areas Accessibility Guidelines, do so because they incorporate specific designed use criteria, as well as design parameters, that provide universal access.

### Trail Design Parameters

Trail Design Parameters convey the dominant criteria that must define the geometric shape of a particular trail. The Howard County Department of Recreation and Parks' Trail Design Parameters are located in Appendix I of this manual. The DRP Trail Design Parameters represent the typical design and construction parameters which the County desires all trails to comply within its jurisdiction. These design standards should be considered with the following criteria in mind;

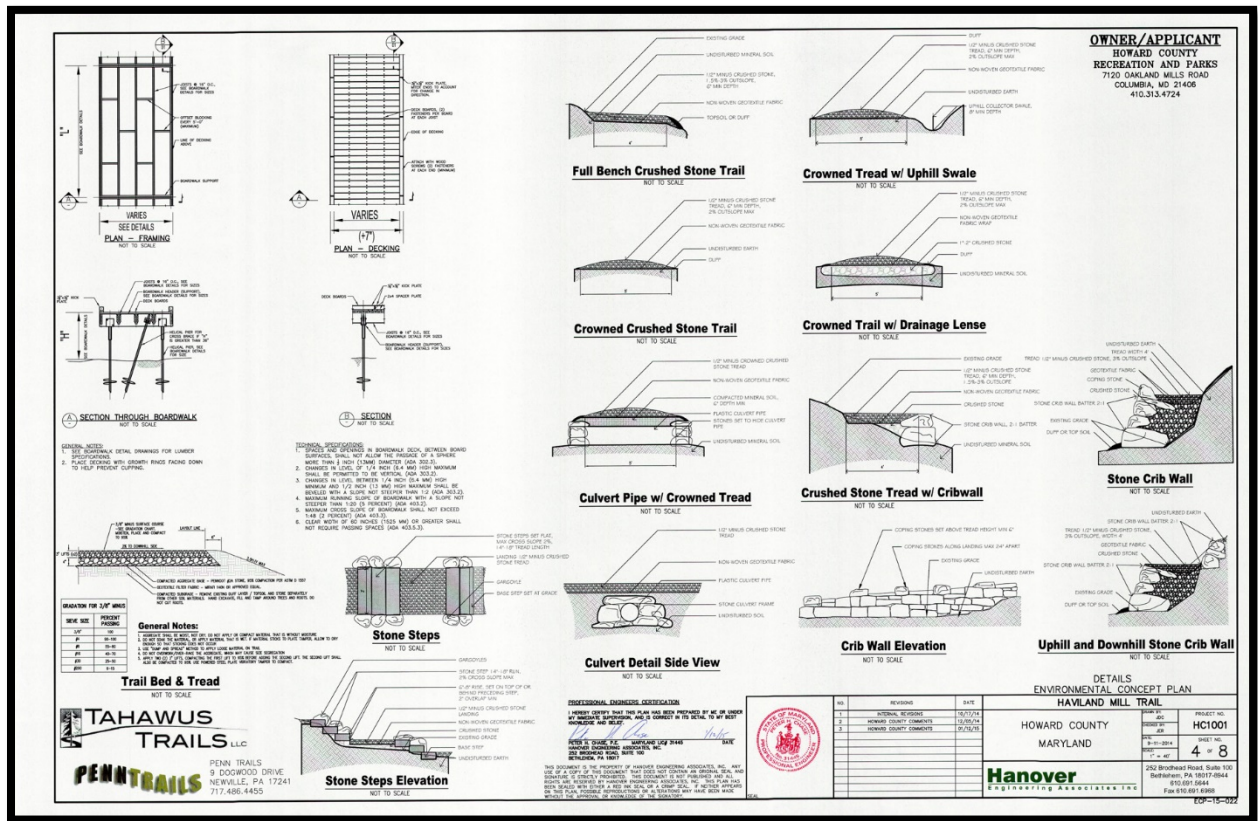

Example: *Trail Design Parameters* for a previous Howard County DRP trail project.

All trail designs should include the following parameters and details.

- A. **Clearing Limit:** The area over and beside the trail tread that is cleared of trees, limbs, and other obstructions.
  - 1. Clearing Height: The height of the clearing limit measured vertically from the trail tread.
  - 2. Clearing Width: The width of the clearing limit measured perpendicular to the trail.
- B. **Cross Slope:** The percentage of rise to length (“run”) when measuring the trail tread from edge to edge perpendicular to the direction of travel.

- C. Design Clearing: The clearing limit determined to be appropriate to accommodate the Managed Uses of a trail.
1. Design Clearing Height: The minimum clearing height determined to be appropriate to accommodate the Managed Uses of a trail.
  2. Design Clearing Width: The minimum clearing width determined to be appropriate to accommodate the Managed Uses of a trail.
  3. Design Shoulder Clearance: The minimum horizontal and vertical clearance of obstructions (for example, removal of bicycle pedal or motorcycle peg bumpers) immediately adjacent to the trail tread that is determined to be appropriate to accommodate the Managed Uses of a trail.
- D. Design Cross Slope: The cross slope determined to be appropriate to accommodate the Managed Uses of a trail.
1. Target Cross Slope: The cross slope that is determined to be appropriate over most of a trail to accommodate its Managed Uses.
  2. Maximum Cross Slope: The steepest cross slope that is determined to be appropriate based on the Managed Uses of a trail and that exceeds the target cross slope of the trail.
- E. Design Grade: The trail grade determined to be appropriate to accommodate the Managed Uses of a trail.
1. Target Grade: The trail grade that is determined to be appropriate over most of a trail to accommodate its Managed Uses.
  2. Short Pitch Maximum: The steepest grade that is determined to be appropriate based on the Managed Uses of a trail, that generally occurs for a distance of no more than 200 feet, and that does not exceed the maximum pitch density.
  3. Maximum Pitch Density: The maximum percentage of a trail with grades that exceed the Target Grade and that are less than or equal to the short pitch maximum, which is determined to be appropriate based on the Managed Uses of the trail.
- F. Design Surface: The trail tread surface, defined in terms of surface type, surface protrusions, and surface obstacles, that is determined to be appropriate to accommodate the Managed Uses of a trail.
1. Surface Type: A characteristic of the design surface expressed in terms of material type, grading, compaction, and roughness of the trail tread.
    - a. Native: A surface composed of soil, rock or other naturally occurring materials found on or near the trail.
    - b. Firm: A surface that is not noticeably distorted or compressed during the seasons for which it is managed, under normally occurring weather conditions, by the passage of a device that simulates a trail user in a wheelchair.
    - c. Stable: A surface that is not permanently affected by normally occurring weather conditions and able to sustain normal wear and tear caused by the uses for which the trail is managed between planned maintenance cycles.
    - d. Surface Protrusions: Trail tread imperfections, such as rock, roots, holes, stumps, steps, and structures, that are within the acceptable range of tread roughness and challenge level for the trail and that do not obstruct the Managed Uses of the trail.
    - e. Surface Obstacles: Trail tread imperfections, such as rocks, roots, holes, stumps, steps, downed logs, and structures, that are beyond the acceptable range of tread roughness and challenge level for the trail and that obstruct one or more Managed Uses of the trail.

- G. Design Tread Width: The tread width determined to be appropriate to accommodate the Managed Uses of a trail.
- H. Design Turn Radius: The minimum horizontal radius required for a Managed Use to negotiate a curve (for example, a switchback, climbing turn, or horizontal turn) in a single maneuver.
- I. Trail Grade: The ascent or descent of a trail segment expressed as a percentage of its length.

## Trailheads

### *Introduction*

Trailheads are important nodes and design elements of a trail system. They provide the first and last impression of the trail system in terms of quality and experience. A cohesive image is important for the recognition of the trails identity. The trailhead user's experience is equally important to promote the use of a trail.

The following guidance is provided to assist in achieving a set of goals and objectives for trailhead design parameters. Trailhead design parameters should also compliment the associated managed and designed uses for the specific trail they are intended to serve.



### *Trailhead Definition*

“A trailhead is defined as an outdoor space that is designated by an entity responsible for administering or maintaining a trail to serve as an access point to the trail.” (United States Access Board F106.5 (Recreation Facilities)). By definition, the intersection of a trail with a road or each other is not considered a trailhead, unless it is designated and designed as such.

### *Trailhead Type*

For the purpose of providing appropriate guidance for the trailhead design in terms of trailhead location, local relevance, size, user, usage and necessary facilities, trailheads are categorized by the following types:

- a. Trailhead in local parks
- b. Trailhead in regional parks.
- c. Trailhead at local community gateways
- d. Trailhead at multi-modal transportation nodes

### *Trailhead Design Goals*

The main design goals of a trailhead to achieve via these guidelines are:

- a. to provide trail users a pleasant, convenient, unique and memorable experience.
- b. to enhance the identity and sense of place at the beginning of a trail.
- c. to ensure safe and easy connection to the trail and other transportation modes.
- d. to provide a place with universal accessibility.

- e. to develop a place that will be context-sensitive, physically, ecologically and culturally.
- f. to create a place that will meet the needs of a diverse range of users in terms of age, gender, race, and physical ability.
- g. to construct a sustainable trailhead.

*Trailhead Function*

Typically trailheads serve, but are not limited to, the following functions for the trail user:

- a. Signals the beginning or end of a trail.
- b. Serves as a meeting place for the user prior to exploring the trail.
- c. Provides a place for rest and relaxing.
- d. Supplies information about the trail.
- e. Guides the user’s experience.
- f. Provides a sense of the quality and ideals of the managing agency.



**Site Planning**

A site plan for trailhead development includes 1) access points, 2) trail user facilities and their locations 3) spaces for activities such as obtaining information, gathering, resting and relaxation, socializing, viewing etc. 4) existing site features preserved, 5) new site features such as landscaping, drainage features, 6) pedestrian route and 7) safety and security measures (emergency phone, fence and gate, etc.) when required. The site plan should show relationships, or a rational, sequential relationship, between these facilities and activity spaces, and an uninterrupted, universally accessible pedestrian circulation.

Generally speaking, preparing a site plan for a trailhead is no different from preparing a site plan for any site development project. Typically, once the trailhead site or alternative sites are selected, site planning will start with existing conditions inventory/survey, followed by assessment and analysis of the site conditions, identifying site development constraints (problems, issues) and development opportunities, developing design concept(s) and preparing a site plan to delineate the concept. Subsequently, this site plan will be developed into design implementation documents for the trailhead construction through sound site design practice. The guidelines for the site design for trailheads are shown in Section 4.0. Stated in the following are important factors to be considered in the site planning process for the trailhead.

*Location*

Prior to developing the site plan, alternative locations of a trailhead may be evaluated. Very often this happens simultaneously as a trail alignment is being assessed. Guidelines for trailhead location selection are shown in Section 3.1

*Understanding the Site*

Once the trailhead location is decided and prior to the development of the trailhead site plan, perform an existing conditions survey and site features inventory. This task typically includes the assessment and analysis of topography, site drainage pattern, utilities, soils, vegetation, wildlife, wetlands, unique features (natural, historical, cultural), access means to the site, connections to trails, adjacent community facilities, and types of user groups.

Based on the site analysis/assessment, site development challenges/constraints will be identified. Typical challenges/constraints include: steep slopes, soils with slow infiltration rate, existence of rare and endangered flora and fauna, floodplains, wetlands, critical streams, access restrictions, overhead and underground utilities, archeological sites or features, and relationships to existing land easements/Right-Of-Ways. When developing the site plan, these challenges, along with the positive features (opportunities) can also be creatively integrated into the plan elements to help shape the character of the trailhead.

### *Features and Amenities*

Features and amenities will be selected to accommodate different types of trailhead as defined earlier.

- Determine the appropriate size and type of trailhead based on type(s) of trail it connects to, transportation means of the trail user, and the projected volume of the trailhead user.
- Decide on type of features and amenities required by the analysis above.
- Assess the level of emergency access needed.

### *Spatial Relationship of Proposed Features and Activities*

Spatial relationships of the proposed features and activities are essential to the trailhead user's experience. Guide the user by providing sequential arrangements of the facilities so there is a smooth transition, without interruption, from one space to another.

- Strategically place directional sign along access route to bring users to the trailhead.
- Place identification sign at access points to announce the site to the users.
- Establish a clear, open area for orienting users to park their vehicles, bikes and/or pedestrians finding the trailhead.
- Organize features so that their basic needs are met before they use the trail.
- Clearly direct user to various facilities, such as parking, drinking fountains, restrooms, gathering spaces, seating and then informational kiosk.

### *Drainage*

Site drainage is another factor that will have impact on the user's experience. Early in the site planning process, natural site drainage patterns should be identified and studied. Site runoff management should follow this pattern to alleviate problems such as puddling or ice formation, undue wear and tear, erosion and constant maintenance. A successful drainage design will provide positive user experience.

### *Access/Connection to trails*

The main purpose of a trailhead is to provide clear orientation, universal access and direct connection to the adjacent trail it serves. The site plan should:

- Identify most direct, easiest and safest routes and sign accordingly.
- Clearly identify connections to existing or proposed trails.
- Provide accessible route to trails and adjacent facilities, such as a parking lot.

### *ADA Compliance/Universal Accessibility*

Once at the trailhead, providing for all types of users in the most accommodating manner possible will allow for an appreciation and respect of the resource. The site plan should

- Identify most direct, easiest and safest routes and provide for most accessible surface material possible.

- Identify connections to existing or proposed trails and make connections to them.

### *Safety/Security*

Apply *Crime Prevention Through Environmental Design* (CPTED) principles to prepare the site plan. CPTED includes strategies implemented to directly modify the environment to take advantage of pre-existing environmental assets or change the design features and condition of particular targets or areas in an effort to ensure user safety.

- Territoriality – promotes the sense of ownership and may include the use of signs, fences, artwork that helps define ownership of a given location.
- Activity Support – encourages legitimate activities in public places to foster opportunities for natural surveillance and may include scheduled gatherings, trail programs/tours, night time events, volunteer clean up days, etc.
- Access Control – restricts access to specific areas and can include the use of barriers, landscaping, fences/gates, changes in circulation patterns, etc.
- Surveillance – increases visibility by natural, formal and mechanical methods such as through promoting routine surveillance by community residents, police patrols; locating areas close to high use areas or roads for an increase in watchability or easier drive-by routine surveillance by police.
- Maintenance – insures the routine maintenance of the area such as clean-up programs or repairs/modifications to meet new threats.
- Target Hardening – adding physical features that will make it more difficult to commit a crime such as the use of lighting, using durable and easy to replace materials.
- Accommodate access by emergency responders to trailhead facilities.

## **Site Selection**

Site selection is crucial for a trailhead to achieve successfully the goals stated in Section 1.3 and to effectively perform the functions stated in 1.4. Selection criteria should include visibility, location, topography, surrounding characters, soils, views, vegetation and cultural heritage and history of the site.

### *Location*

#### Objectives

- To make trails more accessible to the community and other trail users. By bringing the trailhead closer to the community and the spaces where the community would frequently use, the community will be more aware of the recreational resources and views it as an asset.
- To take advantage of the unique site features or characters.

#### Guidelines

- Locate trailheads in the vicinity of accessible routes, rest areas, or parking lots.
- Locate trailheads in existing parks, visitor centers and other open spaces.
- Locate trailheads at places where community services and gathering spaces are.
- Locate trailheads at sites that have unique environmental, ecological, historical or cultural value.

### *Visibility*

In order to provide trail users a sense of welcoming and the starting point of the trail, it is important that the trailhead is at a location that is visible from the approaching route.

#### Objectives



- To select a site that is easily accessible and visible by the trail user.

#### Guidelines

- The trailhead should be sensitively sited, relate well to the surrounding environment and be visible and easy to find when driving, bicycling, or walking/hiking from access routes.
- The trailhead should be open and free of visual barrier from the vicinity of the access route.

#### *Slope/Topography*

##### Objectives

- To select a site with topography that would minimize the grading effort in order to meet ADA requirements and Universal Accessibility.
- To select a site with topography that would provide adequate drainage.

##### Guidelines

- Avoid locating in areas with steep slopes or natural drainage corridors.
- Avoid excessively cutting or filling slopes.
- Preserve natural site landform and drainage patterns where possible, this will minimize site disturbance and damage to surrounding vegetation and concentrating water flows.
- Grading at trailheads should blend topography into the surrounding landscape, prevent erosion, and provide opportunity for water harvesting and infiltration.
- Trailheads topography should be as flat as possible but allow for positive drainage and accessibility for all users.

#### *Surrounding character*

##### Objectives

- To ensure that the trailhead complements and is compatible with its context.

##### Guidelines

- Anticipate usage and traffic volume.
- Study the natural, scenic and cultural aspects of the site.
- Evaluate the surrounding context of the site such as trails, towns, farms, etc.
- Locate and evaluate existing land-uses, and define compatibility of uses in relation to one another.
- Evaluate access, circulation, and parking areas.
- Evaluate existing cultural influences and landscape character.
- Evaluate existing facilities to be worked in with the overall design.
- Accessibility of the site to be ADA or ADAAG compliant.
- Avoid dangerous areas such as steep cliffs, rock fall zone and vehicular traffic.

## *Soil*

### Objectives

- To ensure positive drainage on site.
- To provide firm sub-base for trailhead amenities and surface material.

### Guidelines

- The soil should have good infiltration, thus resisting pooling and ponding
- The surface of the site should be firm, resisting deformation and stable, sustaining normal wear.

## *View*

### Objectives

- To integrate adjacent or remote view and vista into trailhead design.

### Guidelines

- Select a site that takes advantage of the unique scenery and has an attractive and safe setting to enhance a photography opportunity.
- Enhance and protect significant view corridors related to the site.
- Screen incompatible or unsightly views.

## *Vegetation*

### Objectives

- To enhance spatial quality of trailhead site.
- To integrate surrounding features character into the trailhead site.

### Guidelines

- Take advantage of existing plants to provide a comfortable microclimate.
- Consider plants as providing both buffer and habitat for wildlife.
- Use plants to provide edge, texture and screening for the site.
- Use plants to express character, be a softener, unifier, be symbolic and provide ornamental value.
- Use plan to connect, direct, or frame the surrounding views.
- Use plants to define space and enhance spatial quality.

## *Cultural and Historic Heritage*

### Objectives

- To be representative and reflective of the unique cultural and historic heritage that surrounds the trailhead.

### Guidelines

- Materials and the cultural elements in that area influence the design of the trailhead.
- If a trailhead is near a cultural site, integrate it so that it harmonizes with the resource. Use similar construction materials, colors, textures.
- Make a connection either physically or visually.
- Screen conflicting views of the resource.
- Link the surrounding view.
- Add interpretive features to describe the resource, enliven the sites character and engage the user with the site.

## Site Design

### General Features

Trailheads are transition spaces from car zones or other transportation modes to a pedestrian-oriented zone, urban or natural. It provides a spatially defined area, separated from automobile space, which allow people to gather, meet and organize their trip activities.

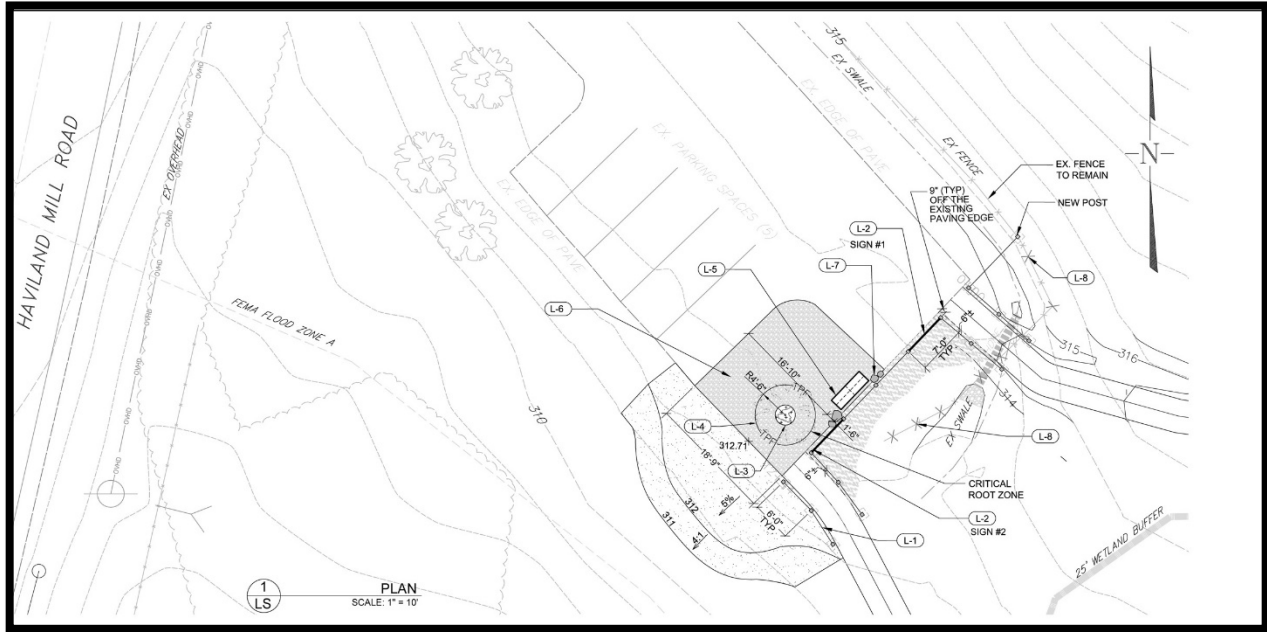

#### a. Surface Material

##### Objectives

- To provide durable trailhead surface.
- Trailhead surfaces are not covered under the 2010 ADA standards, but all amenities are and should therefore meet ADA requirements.

##### Trailhead Surface Guidelines

- Surfaces should be firm and stable and resist deformation when a person walks or wheels across it.
- An improved surface should be made of material that maintains consistent stability over long periods of use.
- Where the surface is concrete, asphalt, or boards, obstacles shall not exceed ½ inch in height measured vertically (Recreation Facilities) where other surfaces are used, they shall not exceed 2 inches in height.
- Where viewing areas are provided, clear ground space shall be provided at each viewing location. The clear space shall be a minimum of 36 inches by 48 inches and shall be positioned for either forward or parallel approach to the viewing location.
- A clear ground space of minimum 30 inches by 40 inches shall be provided for signs, bins, or holders.
- Provide an accessible route to trailhead main area with a minimum of 60" wide and overall grade of 5% and cross slope of 2%.

- Use porous/pervious paving where possible.
- Use natural materials already present at or near the trailhead, such as crushed, local stone.

b. Slope

Objectives

- To select a site with topography that would minimize the grading effort in order to meet ADA requirements.
- To select a site with topography that would provide adequate drainage.

Guidelines

- If the surface is constructed of concrete, asphalt, or boards, the slope of the clear ground must be no steeper than 2% in any direction.
- When the surface of the clear ground is constructed of materials other than concrete, asphalt, or boards, no steeper than 5% are allowed when necessary for drainage.
- Opening in the surface of the clear ground space must be small enough to not allow a sphere more than ½ inches in diameter to pass through.
- It is recommended that the drainage grates be located outside the clear ground space and elongated openings should be placed perpendicular, or as close to perpendicular as possible, to the dominant direction of travel.

c. Markers

Objectives

- To provide for features that acknowledges locations on trails or crossings.

Guidelines

- Use rock, timber or other local materials to mark trail locations or entry's when it crosses a road.
- Use consistent, identifying markers for emergency responders.

*Functional Features*

a. Gateway Feature

Objectives

- To provide a design feature on the trailhead site that would signal the beginning of a trail.

Guidelines

- Create a distinctive structure to indicate trailhead and allow users transiting to the trails through it.
- The design shall compliment the trailhead setting, natural or urban, and be a representation of the trails character.
- The disturbance of the gateway should be very limited, so it would appear as part of the natural setting.
- The gateway feature should be visible and appropriately scaled.
- Secondary portal gates should be provided where the trailheads are hard to find or hidden.
- Gateway features should be of the same character as the trailhead wherever they are used.

b. Waiting Areas

#### Objectives

- To provide a friendly, convenient and comfortable area for trail users to gather or obtain trail information prior to using the trail.
- To provide appropriate facilities for the trail user.

#### Guidelines

- Provide a waiting area of at least 50 to 150 square feet depending on the trailhead type near trailhead entry.
- Provide a welcoming, compact, enclosing space.
- Information shall be provided so the users understand and appreciate the trail setting.
- Locate the information kiosk to be visible from the waiting area and next to it. It shall be at least 24" off trail.
- The information presented depends on the type of trail. Trailhead name, safety and logistical information are recommended.

### *Grading and Drainage*

#### a. Graded slope

##### Objectives

- To comply with ADA requirements.
- To minimize erosions of slopes and grounds.
- To minimize the limit of disturbance of construction activities.

##### Guidelines

- Accessible surface and access from the parking area should be less than 5% overall and 2% cross slope.
- Provide an evenly graded cross slope to prevent water ponding and ice formation.
- Blending the slope of the site and the topography of surrounding to adapt to natural elements of the site.
- Compliment and preserve the landform of the site to provide minimum disturbance and damage.
- Install and maintain the vegetative groundcover or seeding, mulching and sodding adjacent erodible areas to minimize erosion.

#### b. Site Drainage

##### Objectives

- To provide positive drainage throughout the trailhead site.
- To integrate drainage features seamlessly into the trailhead design.
- To effectively manage the stormwater qualitatively.
- To recharge the groundwater where possible.
- To provide cost-effective drainage system.

##### Guidelines

- Direct run-off with a gentle slope towards plants, so it will slow down run-off and allow it to infiltrate in.
- Use drainage swales or mounds to channel water away from the trailhead.

- Prevent fast runoff and evaporation through water management techniques.
- Create small, natural looking check dams, retention and siltation basins, such as raingardens to slow drainage release and to improve water quality. Artistic features can be incorporated into the design.
- Design drainage-ways to appear as a natural depression that allow for water infiltration and absorption.
- Install culverts when necessary to move water from one side to the other.
- Harvest rainwater to re-use stormwater to minimize the need for irrigation.

c. Walls

Objectives

- To minimize the use of walls.
- To use walls when it is required to comply with ADA requirements.
- To select construction material with context sensitivity.
- To ensure user safety.
- To apply sustainable construction methods.

Guidelines

- Construct rock or timber walls to maintain the cross slope of the trailhead surface to be universally accessible, to protect visitors from steep drop-offs, and as retaining walls for steep slopes.
- Avoid walls taller than 2 feet. Terrace slopes if wall is greater than 6 feet. Provide protective fencing along wall taller than 2 feet.
- Natural material seating is suggested to be part of the wall where possible and it is able to support consistent use..

*Space Design*

The first impression of a trail is through the trailhead.

a. Sense of Place and a Memorable Experience

Objectives

- To convey a positive impression of the trailhead.
- To create a strong sense of place for the trailhead.
- To provide information about why the place is special/unique/interesting.
- To provide a memorable experience.

Guidelines - The design of the trailhead to enhance the sense of place by providing:

- A good representation of the existing natural and cultural surroundings.
- Site features/amenities that are special and unique to the site.
- By way of transition to the trail in the way of images, maps, stories, interpretive displays so that the user feels connected with the place.

b. Context Sensitive Design

Objectives

- To acknowledge natural and cultural context of the site.
- To provide designed elements that blend and enhance the surrounding nature.

Guidelines - Context sensitive design acknowledges:

- Seasonal changes, wind, sun, precipitation.
- The sites' unique natural environment.
- The sites' unique cultural and historic heritage.
- Usage of long-lasting native materials.
- Provides for people and ecosystem interaction.

### *Sustainable Design*

Objectives

- To recognize natural and cultural values of the site, appreciate them and promote them through the design parameters.
- To protect and preserve nature.
- To provide a sustainable trailhead.

Guidelines

- Protect and preserve culturally, historically and environmentally sensitive resources, such as plants, geological formation, water, archeological/historic features, etc.
- When trailhead site is located in a natural setting, promote the natural landscape as the theme of the designed landscape of the trailhead.
- Recognize and enhance ecological systems of the site and incorporate it into the trailhead design.
- Specify durable, local materials that have low impact to the environment.
- Provide low maintenance materials and design solutions.

### *Landscape Design*

Locate plants depending on plant growth characteristic, considering wind, sun, slope and water.

#### a. Planting design

Objectives

- To reveal the existing view or site features.
- To enhance the existing view(s) or site features.
- To screen the unsightly view, areas, facilities and other objects.
- To preserve existing natural landmarks and other distinctive features.
- To improve micro-climate of trailhead sites.
- To enhance visual quality and to create high spatial quality of trailheads.
- To provide sensory experience to the trail user.
- To provide shelter and food for the wildlife.

Guidelines

- To selectively prune existing vegetation to reveal the view to distant special features such as water, mountains, buildings and other structures.

- Through planting design to strategically place trees and other plants to frame quality views and vistas.
- Screen unpleasant views to maintenance areas, utilities, storage yards, buildings, billboards, etc. with plants.
- Preserve and protect natural landmarks, such as geologic outcrops, wetlands, specimen trees, groves, and mature rare and endangered plants.
- Use trees and shrubs to provide shade from sun in the summer and shelter from the wind and allow sun in the winter.
- To enhance the visual quality and to ensure the safe and informed user experience, the following planting design considerations using native plants shall be incorporated into the planting design.
  - Provide visual and physical transition from vehicular space to pedestrian space and to the trail or natural setting.
  - Guide visitor movements for both physical barrier and visual indication.
  - Use native plantings that looks appealing with the use of color, texture or character of plants to physically and visually orient the user to the entry point and other interests.
  - Direct visitor's movements away from hazardous areas, using unauthorized areas, exits or access points.
  - Maintain the uninterrupted line of sight using groundcover and shrub height with a maximum mature height of 3' above ground level.
- Place native plants with special qualities of color, sound, smell, or motion close to visitor facilities.
- Through planting design and use native plants that provide shelter and food for wildlife to further enhance the user's experience.

b. Plant Species Selection

Objectives

- Use plant material to be reflective of adjacent site characteristics and local heritage.
- Use plant material that will thrive in the trailhead environment.

Guidelines

- Select local, native plants present at or around the sites.
- Consider soil moisture, water, sun exposure, orientation, wind, slope and elevation.
- Habitat, food needs and shelter for local wildlife should be part of design consideration.
- Nursery supplied plants should come from a similar climate setting. Local nurseries are recommended.
- Species that recover quicker from disturbances such as heavy snow, fire and drought should be considered.
- Group plants to mimic natural habitats and also to provide seasonal interest year round.
- Cluster plants with natural companions to sustain their health. They may also provide nutrients for the others and/or sun and wind protection.

*Site Furnishings and Amenities*



A minimum of 20% of site furniture must comply with the technical requirements for outdoor constructed features of ADAAG. (<https://www.access-board.gov/guidelines-and-standards/buildings-and-sites/about-the-ada-standards/ada-standards/chapter-2-scoping-requirements>).

a. Materials

Objectives

- To relate the selected materials to the surrounding environment, character, history and heritage.
- To select the materials that are cost-effective to build, maintain and are sustainable.

Guidelines

- Build trailheads with natural materials already present at or nearby the trailhead.
- The trails, accessible routes and waiting areas should be built out of crushed, local stone where appropriate.
- Permanent elements should be constructed from rock, or timber/logs depending upon the availability.
- Permanent elements made of metal should be coated with a durable, paintable and protective coating.

b. Kiosk

A trailhead kiosk serves as the first and last impression for the trail. They indicate arrival, welcome visitors and provide them with information that may be essential to their safety and enjoyment on the trail. It describes the material, condition, length and complexity of the trail.

Objectives

- To install kiosk suitable for the type of trailhead that would provide adequate information for trailhead users.
- To integrate kiosk into the place-making vocabulary.

Guidelines

- Locate information/orientation kiosk next to waiting area, at least 24" off trail.
- Indicate trailhead name and necessary information.
- Coordinate material, style, and colors with other site features.

c. Seating

Objectives

- To integrate seating into the place-making vocabulary.
- To provide an amenity for rest or to wait for others to gather.

Guidelines

- Build in a small seating area made of local materials of at least 18 inches high and a minimum of 30 inches deep and 48 inches wide, some with a back to comply with ADAAG requirements
- At least 20% of the seating shall be ADAAG compliant.
- Reserve a 36"x 48" area of clear ground positioned near the bench with one side of the space adjoining the access route or the trail. The clear ground may not overlap another clear ground, trail or the access route.

- Providing a bench with one armrest and back support that runs the full length of the bench is recommended. Armrest in the middle or located at one end farthest from the clear ground is recommended.

d. Picnic table

Objectives

- To integrate picnic tables into the place-making vocabulary.
- To provide an amenity for rest, to eat or to wait for others to gather.

Guidelines

- Minimum of 36 inches of clear ground on all usable sides of the picnic table from the back edge of the seats or benches shall be provided.
- At least one wheelchair seating space a minimum of 30 by 40 inches must be provided for each 24 linear feet of usable space around the perimeter of a tabletop. (one for tables up to 9 feet long and 2 for 10 -20 feet long tables)
- The wheelchair space must be positioned for a forward approach and provide knee and toe clearance under the table. (See 306 of ABA standards).
- Knee clearance must be at least 30 inches wide and 8 inches deep at 2 inches above the ground surface.
- Toe clearance must be at least 30 inches wide and 17 inches deep and extends at least 9 inches above the ground surface.

e. Trash receptacles and recycling containers

Objectives

Per Howard County Code Title 18. Public Works. Subtitle 6A Solid Waste Collection. Sec 18.612.

- To integrate trash receptacles into the place-making vocabulary.
- To provide adequate capacity, size and number.

Guidelines

- 36 by 48 inches of clear ground positioned for a forward approach to the receptacle opening or 30 by 60 inches positioned for a parallel approach to the receptacle opening.
- The operable parts of the trash and recycling containers, such as handles and latches, must be between 15 and 48 inches above the ground. The operable parts must also be operable using one hand without tightly grasping, pinching, or twisting the wrist, and with no more than 5 pounds force. If products with the above specs are not commercially available (Let's check), compliance is required to the extent practicable.

f. Fencing and Gates

Objectives

- To provide a barrier.
- To provide a sense of entry to the trail.
- To define the trailhead area.
- To provide a sense of safety between vehicular/pedestrian or hazardous areas.
- To integrate fencing and gates into the place-making vocabulary.

#### Guidelines

- Keep to a minimum, as they can be distracting from the surrounding environment.
- To contain traffic and wildlife flow or too keep vehicles off of sensitive areas, fences and gates can be used.
- Fence wildlife from the trailhead in areas subject to browsing. Consider wildlife movement through the site when locating the fence.
- Consider log worm fences or simple buck and pole fence in stony areas where it is difficult to dig post holes. Timber post and rails, 3 rails, in other areas are recommended but, should be culturally consistent with surroundings.

#### g. Bike Racks

##### Objectives

- Provide trail users a place at trailheads to secure their bikes, if bicycle is the transportation means of the trail user.
- To integrate bike rack into the place-making vocabulary.

##### Guidelines

- Coordinate material, style, and colors with other site features.
- Locate a bike rack next to the waiting area, at least 24" off trail.
- It should be made of durable and appropriate materials to the site.

#### h. Shelter

##### Objectives

- To provide trailhead shelters to serve as protection from the weather for kiosks, other amenities and users.

##### Guidelines

- Provide shelter with durable and context appropriate materials for trail users. It can be as small as a bus shelter or as large as a picnic shelter.
- Coordinate material, style, and colors with other site features.

## **Trail Documentation & Mapping Standards**

### *Howard County Recreation & Parks Trail System*

The collection, storage, and management of trail-related data are important components of everyday business activities in many Federal, State and local land-managing agencies and trail organizations. From a management perspective, trails data must often mesh closely with other types of infrastructure, resource, and facility enterprise data. For the public using paper maps, the internet, GPS or other instrumentation, standard data formats enable users to consistently and predictably identify specific trails and a core set of corresponding information. Today, digital trail data are a necessity throughout a trail data management life cycle, from trail planning through design, construction, operation, and maintenance.

Data collection is the process of gathering information in an established systematic fashion. Howard County Department of Recreation and Parks in collaboration with Penn Trails LLC has developed a GPS driven system for systematic collection in 2016. The system includes a comprehensive dictionary of all trail features and the information attributes to be collected. The dictionary is represented in excel format and in Terrasync™ Software on the Trimble 6000 unit. The excel dictionary includes all feature definitions, attribute parameters, photographs and diagrams as reference for the collection technician. The dictionary in the Terrasync™ Software on the Trimble 6000 unit is the field collection version.

Information attributes can be downloaded and viewed with the MapInfo mapping software to assist Park Managers access existing conditions and plan for maintenance projects.

### *Developer Proposed Trails on Dedicated County Open Space*

Department of Recreation and Parks

General Conditions for Right-of-Entry and License Agreements

For Trail and Pathway Construction & Maintenance on Open Space

The following terms and conditions will be included in all agreements where Howard County Department of Recreation and Parks (the Department) grants the permission to use County-owned property for Trail and Pathway Construction and Maintenance on parklands. Parklands include open space, natural resource areas, developed parks and undeveloped parks. These conditions are to be included on all construction drawings. A copy of all agreements will be filed with the Real Estates Services Division of the Department of Public Works.

- 1). No Right-of-Entry or License Agreement will be granted until the Department of Recreation & Parks reviews and approves the plans for the proposed project.
- 2). Submitted plans must also be approved by the County. This means the plans will go through the standard Subdivision Review Committee process.
- 3). The Developer or entity submitting the request shall schedule an on-site meeting with the Department of Recreation & Parks to review the stakeout of the proposed project and construction access points. It is recommended that this meeting occur prior to submitting plans for Site Development Plan review.
- 5). For proposed projects that appear on a County Approved SDP, the Developer must post the County property and place an advertisement in a local newspaper in accordance with Howard County Code, Title 18, Subtitle 1, Section 18.112 (f) which states “The posting and advertisement shall describe the project and state the telephone number of the developer or property owner where the citizens may call for further information and shall also provide a two-week period for such inquiries
- 6). Prior to the County executing the Right-of-Entry or License Agreement, the Developer will be responsible for a forest restitution assessment as reimbursement for trees and habitat destroyed and areas

disturbed. The forest restitution assessment is computed at \$1.20 per square foot and non-forested areas at \$0.75 per square foot multiplied by the number of square feet within the right-of-entry area. A habitat loss fee will also be levied on all projects of a minimum rate of \$250.00 per 0 - 5,000 square feet of disturbance. Projects over 5,000 square feet, fees will be rounded up to the next 5,000 increment. Evaluation/Administrative Fee: Calculated at \$250.00 per 0 - 10,000 square foot increment. Projects over 10,000 square feet, fees will be rounded up to the next 10,000 increment. The restitution assessment is due upon prior to the execution of the Right-of-Entry Agreement and will be adjusted to reflect the actual area disturbed.

Note: For Trail and Pathway Construction projects – The fee area shall include a 4 foot LOD on each side of the corridor alignment, temporary access and any other areas of impacted by construction activities.

Restoration payment must be submitted to the Department of Recreation and Parks prior to receiving a Right-of-Entry agreement. Please make check payable to: Director of Finance and send to the following address:

Department of Recreation and Parks  
Natural & Historic Resources Division  
7120 Oakland Mills Road  
Columbia, MD 21046  
ATTN: Brenda Belensky

7). The Department of Recreation and Parks shall be contacted no less than ten (10) days prior to a contractor entering the premises to commence any activity other than survey work. Contractor shall contact Brenda Belensky (410) 313-4724 or [bbelensky@howardcountymd.gov](mailto:bbelensky@howardcountymd.gov)

8). The Department of Recreation and Parks shall decide the ultimate disposition of all trees removed.

9). Trail construction within the approved LOD easement shall follow all SCD sediment and erosion protocols as recommended within the 2017 Howard County Trail Planning and Management Guide must be fenced prior to the start of construction.

10). During construction, if the developer needs to expand the LOD shown on the executed Right-of-Entry Agreement, the developer must perform the following:

a. Must contact the Department of Recreation and Parks for approval.

b. If a change is approved, a redline drawing must be submitted to the Department of Recreation and Parks and the Development Engineering Division in the Department of Planning and Zoning.

c. If construction proceeds outside of the limits of disturbance shown on the plan within the executed Right-of-Entry Agreement without approval from the Department of Recreation and Parks, the Developer will be responsible for a penalty of \$1.20 per square foot for all areas disturbed outside of the limits of disturbance shown within the executed Right-of-Entry Agreement.

11). The developer shall exercise their best efforts to save trees immediately adjacent to the construction area. Where necessary, protective padding will be wrapped around tree trunks to prevent damage by machinery. No equipment or materials shall be parked or stored underneath the canopy of trees or on any park property.

12). All areas with exposed soil, shall be seeded and mulched to stabilize using standards outlined within the approved plan.

13). The developer shall complete construction on County property within 100 days of the executed right of entry agreement. Upon completion of construction, the developer agrees to restore the area in accordance with the approved plan. The Department of Recreation and Parks shall be contacted to schedule a final review and on site walk through. At this time, the County shall confirm the completion of agreed upon work and compliance.

14). The scope of the permission granted by the County to act on parkland property is expressly limited to the terms of this agreement and any plans, approved by the Department. In the event, that a Grantee, its' employees, agents, or contractors deviates from this agreement or the approved plans, the County, in addition to other remedies set forth in this agreement, make take any enforcement action available to it by lay, including the imposition of Civil Penalties under the Parklands, Open Space, and Natural Resource Regulations of the Howard County Code.

15). In accordance with Section 19.211, the County may seek and obtain restitutions from Grantee, its' employees, Agents, or Contractors for all costs incurred in restoring, repairing, replacing or otherwise mitigating the loss or damage to any natural resources or other parkland property destroyed, damaged, altered, or removed.

16). A license agreement will be created by the Office of Real Estate Services to document all the agreed to terms and conditions the County will allow the licensee to pursue to include but not limited to all costs and expenses to construct, maintain, repair, replace and remove improvements and for performing the work.

## Section III - Trail Maintenance

Sustainable trail planning, design and construction does not mean that ongoing maintenance is not required. Maintenance is essential to enabling long term sustainable use of trails, by the intended users, at the level of service that was originally projected.

Contemporary trail maintenance standards should utilize recognized, sustainable best management practices in the maintenance of trails for their particular *managed and designed uses* [See Trail Planning and Management Fundamentals (p.39)] Trail maintenance should not alter or change the intended Trail Management Objectives for a specific trail unless otherwise approved and directed by the Department of Recreation & Parks. Cursory guidance is given in the Howard County Department of Recreation & Parks Trail Management Policy (TMP) and the Trail & Pathway Management Manual (TPMM). The TMP and TPMM is developed and reviewed by the Howard County Department of Recreation & Parks Trail Network Team. Activities that go beyond standard maintenance practices will require the approval of Howard County Department of Recreation & Parks, Natural Resource Conservation Manager.

Seasonal trail maintenance activities should always be concerned with controlling water flow and maintaining a stabilized trail tread. Such practices should include the following:

- Maintaining drainage structures such as swales, culverts and related erosion control structures.
- Water management such as maintaining grade reversals, grade dips, nicks and waterbars to divert water off of the trail.
- Trail tread repair to maintain stable tread surfaces, be they natural, aggregate or paved.
- Clearing, brushing, pruning, grubbing and mowing to maintain height and width clearances for trail corridors.
- Maintaining bridges and other structures.
- Maintaining signage and blazing.
- Invasive species removal.

Note that removal of invasive species may at times require replanting of native trees, shrubs and herbaceous perennials where invasive plants/vines have outcompeted their native counterparts. Allowing more space for natives coupled with consistent monitoring of invasive plants in the beginning should result in less invasive species management over time.

Maintenance activities should be scheduled at a specific frequency that addresses maintaining a trail for its intended use and level of service. Standard maintenance should be coordinated by the park manager and executed within the guidelines and practices directed within the guide.

The following resources are recommended as excellent guides for planning and executing trail maintenance practices that are supportive of the trail planning and management objectives established by the Howard County Department of Recreation and Parks. They are easily obtained through the links provided.

- Pennsylvania Trail Design & Development Principles: Guidelines for Sustainable, Non-motorized Trails, Pennsylvania Department of Conservation & Natural Resources, 2013. [http://www.dcnr.state.pa.us/cs/groups/public/documents/document/dcnr\\_20028130.pdf](http://www.dcnr.state.pa.us/cs/groups/public/documents/document/dcnr_20028130.pdf)
- Universal Access Trails and Shared Use Paths Design, Management, Ethical, and Legal Considerations, Pennsylvania Land Trust, 2014. [http://conservationtools.org/library\\_items/1345](http://conservationtools.org/library_items/1345)
- Trail Planning, Design, & Development Guidelines. State of Minnesota, Department of Natural Resources, 2007. Trails and Waterways Division. <http://www.dnr.state.mn.us/index.html>.
- Equestrian Design Guidebook for Trails, Trailheads and Campgrounds. December 2007. US Department of Agriculture, Forest Service - Missoula Technology and Development Center. <http://www.fhwa.dot.gov/environment/Fspubs/07232816/index.htm>



- Trail Maintenance Manual, 7th Edition Revised. 2007. New York-New Jersey Trail Conference, Inc. <http://www.nynjtc.org/volunteers/vresource.html>.
- Trail Construction and Maintenance Notebook. 2007 Edition. Forest Service, US Department of Agriculture. <http://www.fhwa.dot.gov/environment/fspubs/07232806/index.htm>.
- Lightly on the Land: The SCA Trail-Building and Maintenance Manual. 2006. Robert C. Birkby, The Student Conservation Association. <http://www.thesca.org/about>

## Trail Monitoring

Similar to the goal of trail maintenance, an annual trail monitoring process is being established for Howard County land management units that contain trails of any type. Whether planned and designed, or user created, all trails that are in use will require monitoring. A monitoring process should consist of;

- (1) An initial trail assessment process, utilizing the 2016 Howard County Recreation & Parks Trail Assessment Process and Database.
- (2) A scheduled, annual inspection of all trails within each land management unit.
  - i. Inspection should be based upon either specific Managed Use, Designed Use & Design Parameters developed for that trail, or, proposed Managed Use, Designed Use & Design Parameters developed per this guide.
- (1) In addition to Managed Use, Designed Use and Design Parameters being monitored, it is important to identify and report;
  - i. Conflicted uses,
  - ii. Unsafe conditions,
  - iii. Invasive species.

## Maintenance Scheduling and Documentation

The objectives of trail maintenance are to provide for user safety, access, and convenience, protect natural resources, and preserve trail sustainability. Maintenance begins immediately following trail construction and is a continuous process.

Trail maintenance tasks include the following general maintenance categories

### Trail Maintenance-Vegetation:

- Brushing/clearing areas
- Remove fallen trees/branches
- Hazard tree removal
- Slope revegetation
- Vista maintenance

### Trail Tread Maintenance:

- Grading tread
  - Berm removal
  - filling erosion
  - grubbing rocks/ roots/stumps
- Back-slope shaping/grooming
- Surface replacement according to TMOs
- Surface repair according to TMOs
- Remove obstructions and protrusions according to the trail's TMOs

### Structure Maintenance:

- Bridge repair
- Cribbing/retaining wall repair
- Barrier/guardrail repair
- Steps repair



- Fence/gate/bollard repair
- Kiosk repair

**Sign Maintenance:**

- Sign repair/rehabilitation
- Sign replacement
- Blaze repainting and maintenance

**Drainage Maintenance:**

Cleaning/repairing structures

- culverts
- swales, dips and nicks
- waterbars
- drainage ditches
- Replace or newly install drainage structures



## Trail Closures<sup>v</sup>

Sometimes the best solution for poorly planned and constructed trails, that are experiencing serious erosion and damaging the local environment, is closing the trail and replacing it with a new, sustainable, trail per the processes described in this guide. Trail closures should utilize the same form, for New Trail Proposals, providing the appropriate information and data as related to each trail. Howard County Department of Recreation & Parks desires to reduce mileage of poorly performing, eroding and unsustainable trails when any new trails are considered.

A critical aspect of any re-route project is closing and reclaiming the old route. Eight important elements, to be addressed in any trail closure, include the following considerations;

### 1. Create an outstanding new route.

A key component of any trail closure plan is creating a sustainable alternative that will meet current and future community demands. The new trail must serve users needs. Otherwise the public will continue to use the original trail.

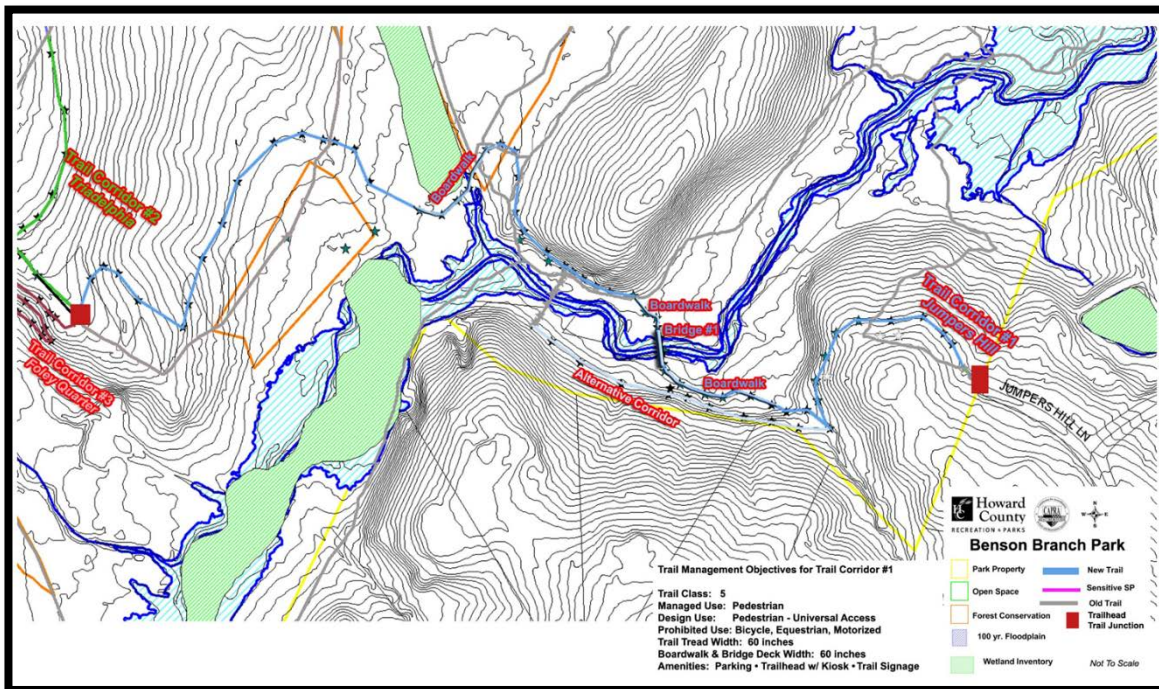

### 2. Design a smooth intersection.

If closing and rerouting a segment of a longer trail, make certain to create seamless transitions with the new section and the larger trail.

### 3. Educate trail users.

Make sure that, prior to closure, plans and signage are in place to educate the public as to why a trail must be closed. Make sure to communicate about what will be happening, when it will take place and what will be replacing the trail or trail segment. Post signs to let people know what changes will be taking place. Ask

for public feedback. Once work is complete, post maps showing the new trail and explaining why the old trail is closed. Be positive and focus on the benefits of the re-route.

#### 4. Break up the old tread.

Completely break up and scarify the compacted soil in the old trail tread. This is necessary to allow the seeds and roots of new plants to penetrate. These areas will be highly susceptible to the establishment of opportunistic invasive species (from both surrounding areas and existing seed bank) and should also be monitored before, during and after step 6.

#### 5. Control erosion.

It is essential to stop water flowing down the old trail route. Erosion control measures fixed across the trail will help to trap soil. A wide range of manufactured erosion control materials are available and designed to absorb water while providing an ideal microclimate for the growth of vegetation. These include straw wattles, erosion control blankets and commercial mulches that combine fiber, seed, and fertilizer. Be sure check dams are embedded below grade, and high enough, to trap the soil, slow water velocity and not wash away

#### 6. Transplant vegetation.

Starting plants on the old trail is the best way to restore the landscape. Disturbed soil often provides an opportunity for invasive plant species to take hold. Combat invasive growth by planting only native species. Transplant shrubs and small trees from your re-route construction.



#### 7. Disguise the corridor.

The best way to keep people off the closed trail is to make it look like it was never there. Your goal is to eliminate the visual corridor, including the airspace above the old trail tread. Drag logs and branches across the tread, placing them in a crisscross pattern, with organic materials placed within the pattern. Rake leaves and other organic matter on to the corridor as the final step to complete the closure and aid new plants.

#### 8. Block the corridor.

Consider whether blocking the beginning and end of the trail corridor, with a fence and signs, is necessary. For heavily travelled trails it may very well be needed. The fence will look out of place, and could draw more attention to the closure. As previously stated, answer expected questions by posting signage explaining the closure on, or near, the fence. When the trail has been closed for several weeks the fence can be removed.



# APPENDICES

## APPENDIX I: Howard County Trail Design Parameters

All trails are not created equal. Ideally, each trail is designed, constructed, and maintained to meet certain specifications. Design Parameters should provide specifications that clearly support the trail’s long term physical, ecological, economic and recreational sustainability [see *Principles of Sustainability* in this guide].

The following Trail Design Parameters are based on *typical* recreational activities that the Howard County Department of Recreation & Parks considers for the specific Designed Use. Trail planning, construction and ongoing maintenance will be guided by these design parameters, which should be utilized as a starting point to inform the specific design, for a specific trail. In addition to these parameters, it is equally important to consider level of service, physical characteristics of the land, ecological and esthetic considerations for each particular trail.

### A. PEDESTRIAN TRAILS

Designed Use HIKER/PEDESTRIAN		Trail Class 3	Trail Class 4	Trail Class 5
Design Tread Width	Singe Lane	36"	48"	60"
	Double Lane	48"	60"	72"
	Structures (Minimum Width)	36"	48"	60"
Design Surface <sup>3</sup>	Type	<ul style="list-style-type: none"> <li>Native with some onsite borrow or imported material where needed for stabilization, occasional grading</li> <li>Intermittently rough</li> </ul>	<ul style="list-style-type: none"> <li>Native with improved sections of borrow or imported material, routine grading</li> <li>Minor roughness</li> </ul>	<ul style="list-style-type: none"> <li>Likely imported material, routine grading</li> <li>Uniform, firm, and stable</li> </ul>
	Protrusions	≤ 3" May be common, not continuous	≤ 2" Uncommon, not continuous	No protrusions
	Obstacles (Maximum Height)	8"	6"	No obstacles
Design Grade <sup>3</sup>	Target Grade	3% – 12%	3% – 8%	1% – 5%
	Short Maximum Pitch	15%	10%	8% Universal Access BMPs = 5% – 8.33%
	Maximum Density Pitch	10% of the trail	10% of the trail	0% – 5% of the trail
	Target Cross Slope	5% – 7%	3% – 5%	2% – 3%



Designed Use HIKER/PEDESTRIAN		Trail Class 3	Trail Class 4	Trail Class 5	
Design Cross Slope				(or crowned)	
	Maximum Cross Slope	7%	5%	3%	
Design Clearing	Height Width	8'	8'	10'	
		36" – 60"	48" – 72"	96"	
	Shoulder Clearance	12"	12"	12"	
Design Turn	Radius	4' – 8'	4' – 8'	6' – 12'	

**B. BICYCLE TRAIL**

Designed Use BICYCLE		Trail Class 3	Trail Class 4	Trail Class 5	
Design Tread Width	Single Lane	36"	48"	60"	
	Double Lane	48"	72"	120"	
	Structures (Minimum Width)	48"	72"	120"	
Design Surface	Type	<ul style="list-style-type: none"> <li>Native with some onsite borrow or imported material where needed for stabilization, occasional grading</li> <li>Intermittently rough</li> <li>Sections of soft or unstable tread on grades &lt; 5% may be present, but not common</li> </ul>	<ul style="list-style-type: none"> <li>Native, routine grading with improved sections of borrow or imported materials</li> <li>Stable with minor roughness</li> </ul>	<ul style="list-style-type: none"> <li>Likely imported material, routine grading</li> <li>Uniform, firm, and stable</li> </ul>	
	Protrusions	$\leq 3''$ May be common, not continuous	$\leq 3''$ Uncommon, not continuous	$\leq 2''$ Uncommon, not continuous	

	<b>Obstacles</b> (Maximum Height)	10"	8"	No obstacles
<b>Design Grade</b>	<b>Target Grade</b>	2% – 10%	2% – 8%	2% – 5%
	<b>Short Pitch Maximum</b>	15%	10%	8%
	<b>Maximum Pitch Density</b>	10% of trail	15% of trail	10% of trail
<b>Design Cross Slope</b>	<b>Target Cross Slope</b>	3% – 8%	3% – 5%	3%
	<b>Maximum Cross Slope</b>	8%	5%	3%
<b>Design Clearing</b>	<b>Height</b>	8'	10'	10'
	<b>Width</b>	60" or 72"	72" or 96"	84" or 144"
<b>Design Turn</b>	<b>Radius</b>	4' – 8'	8' – 10'	8' - 16'

**C. EQUESTRIAN TRAIL**

<b>Designed Use</b>		<b>Trail Class 3</b>	<b>Trail Class 4</b>	<b>Trail Class 5</b>
<b>EQUESTRIAN</b>				
<b>Design Tread Width</b>	<b>Single Lane</b>	60" 60" or greater along precipices	72" 72" or greater along precipices	<b>NOT APPLICABLE</b>
	<b>Double Lane</b>	84"	120"	
	<b>Structures</b> (Minimum Width)	Other than bridges: 84" Bridges without handrails 84" Bridges with handrails: 84" clear width	Other than bridges: 72" Bridges without handrails: 120" Bridges with handrails: 120" clear width	
<b>Design Surface<sup>2</sup></b>	<b>Type</b>	<ul style="list-style-type: none"> <li>Native with some onsite borrow or imported material where needed for stabilization, occasional grading</li> <li>Intermittently rough</li> </ul>	<ul style="list-style-type: none"> <li>Native, with improved sections of borrow or imported material, routine grading</li> <li>Minor roughness</li> </ul>	
	<b>Protrusions</b>	≤ 3"	≤ 3"	

Designed Use				
EQUESTRIAN		Trail Class 3	Trail Class 4	Trail Class 5
		May be common, but not continuous	Uncommon, not continuous	
	<b>Obstacles</b> (Maximum Height)	6"	3"	
<b>Design Grade<sup>2</sup></b>	<b>Target Grade</b>	3% – 10%	2% – 8%	
	<b>Short Pitch Maximum</b>	15%	10%	
	<b>Maximum Pitch Density</b>	15% of trail	10% of trail	
<b>Design Cross Slope</b>	<b>Target Cross Slope</b>	3% – 5%	2% – 5%	
	<b>Maximum Cross Slope</b>	5%	5%	
<b>Design Clearing</b>	<b>Height</b>	120"	120"	
	<b>Width</b>	72" – 96"	192"	
	<b>Shoulder Clearance</b>	12" if needed	12" if needed	
<b>Design Turn</b>	<b>Radius</b>	6' – 8'	8' – 10'	

## **APPENDIX II: Trail Assessment Process**

Howard County Department of Recreation & Parks has developed its own internal Trail Assessment process that utilizes a data dictionary / GPS-based recording and documentation system. For more information, please contact the Natural Resource Conservation Manager, Brenda Belensky (410) 313-4724 or [bbelensky@howardcountymd.gov](mailto:bbelensky@howardcountymd.gov)

## APPENDIX III: Trail Proposal Form

### HOWARD COUNTY DEPARTMENT OF RECREATION & PARKS TRAIL PROPOSAL AND EVALUATION FORM



1. *Requester's Information and Contact:*

2. *For Howard County Departments and Bureaus Only*

**Facility Name:**  
**District Manager Contact:**  
**Email:**  
**Telephone:**

3. *For Developers & Contractors Only*

**Project Name:**  
**Parcel ID:**  
**Company Name:**  
**Project Manager Name:**  
**Email:**  
**Telephone:**

4. *Description of Proposed Trail(s):*

Is this an: Upgrade of existing ( ) Relocation of existing ( ) New trail ( ) Change in Use ( ) Closure ( )

Length: \_\_\_\_\_

Howard County Department of Recreation & Parks desires to reduce mileage of less sustainable trails when any new trails are considered. Will the proposed trail(s) replace current, unsustainable, trail(s) or add to trail inventory of Howard County?

What are the Trail Management Objectives for the trail(s)? Please provide TMOs for each trail.

a. Managed Use?

b. Designed Use?

c. What are the proposed Design Parameters for the trail(s) based upon a and b above?

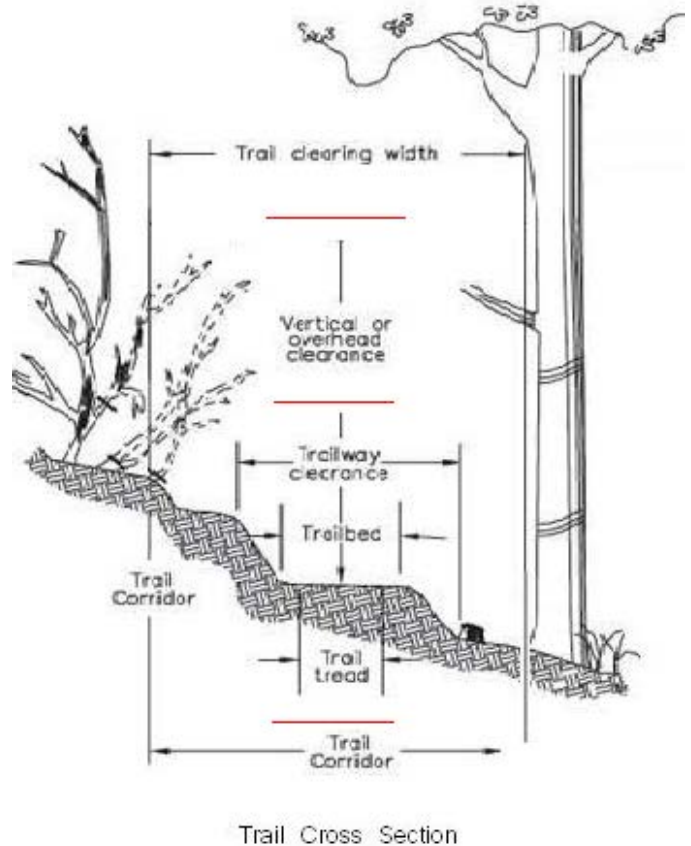

What are the proposed Maintenance Standards for the proposed trail?

**5. Location of Proposed Trail:**

Attach a detailed map of the proposed trail location. Map should show contours, wetland resources, vernal pool, priority habitat for rare species, etc. as detailed in the 2016 HOWARD COUNTY TRAIL PLANNING AND MANAGEMENT GUIDE.

**6. Wetland and Stream Crossings:**

Will there be any new wetland or stream crossings on this trail?

If so, please describe in details (type, length, material) and include drawing of the proposed design.

**7. Signage and Marking:**

What trail signage and wayfinding is proposed? Please include examples and/or references to the 2016 HOWARD COUNTY TRAIL SIGNAGE & WAYFINDING GUIDE.

**8. Support and Success of Trail Project**

Who supports this initiative?

What is the evidence for the demand or need for this project?

Who will construct / complete these improvements?

What materials or other costs are associated with this project and how will these be funded?

Who will maintain this trail project for future use according to the 2016 HOWARD COUNTY TRAIL PLANNING AND MANAGEMENT GUIDE?

**HC DRP REVIEW OF PROPOSED TRAIL PROJECT (To completed by HC DRP staff)**

**1. How does the proposed trail(s) project support existing Howard County Department of Recreation & Parks current and future trails related objectives and plans?**

- *If not, is it supported by operations and planning staff? Should it be pursued?*

**2. Is it embodied in the 2016 Howard County Trail Planning & Management Guide?**

**3. What are the potential short and long term management issues associated with this project?**

- Design, construction and maintenance issues:
- Management issues (abutter concerns, user conflicts, safety, resource impacts):

**4. Will the trail(s) meet Universal Accessibility for Trails best management practices?**

5. *Site Evaluation*

- Discuss issues with the location topography, steepness and trail alignment, and possible alternatives:
- Discuss Historic, Cultural or Archeological resources, impacts or issues:
- Discuss Forestry Management impacts or issues:
- Rare, Species or Natural Communities, potential species and management issues.
- Wetland and Stream Crossings: Discuss wetland issues, vernal pools, stream crossings.
- Discuss other potential impacts or conflicts:

6. **Permitting: Maryland and Howard County Regulatory Review Checklist**

7.

Yes  No Will any of the work require digging, grading, pulling or scaring of ground surfaces? If “yes”, explain in detail with an attached page to this document.

Yes  No Will any work occur within 200 feet of a stream or river or within 100 feet of a wetland resource? If “yes”, explain in detail with an attached page to this document.

Yes  No Does the project area intersect with any Priority Habitat Area? If “yes”, explain in detail with an attached page to this document.

\*For additional information on permitting, please see Howard County Department of Recreation & Park 2016 TRAIL PLANNING AND MANAGEMENT GUIDE.

**Approval:**

**HC DRP Facility Supervisor**  
Comments / Recommendations:

Approve ( )      Disapprove ( )

Signature: \_\_\_\_\_

Date: \_\_\_\_\_

**DRP Forester**  
Comments / Recommendations:

Approve ( )      Disapprove ( )

Signature: \_\_\_\_\_

Date: \_\_\_\_\_



**DRP Natural Resources Manager**  
Comments / Recommendations:

Approve ( )      Disapprove ( )

Signature: \_\_\_\_\_

Date: \_\_\_\_\_

**HC DPZ**  
Comments / Recommendations:

Approve ( )      Disapprove ( )

Signature: \_\_\_\_\_

Date: \_\_\_\_\_

**DLD**  
Comments / Recommendations:

Approve ( )      Disapprove ( )

Signature: \_\_\_\_\_

Date: \_\_\_\_\_

## APPENDIX V: Federal Trail Data Standards (“FTDS”) For Trail Class







In 2009, the Federal Government outlined the need for trails database schema in their Data Standards Review Committee, stressing the efficiency in management decisions that a streamlined database can provide.

*“The collection, storage and management of trail related data are important components of everyday business activities in many federal and state land-managing agencies, trail organizations and businesses. From a management perspective, trails data must often mesh closely with other types of infrastructure, resource and facility enterprise data.”*

On September 30, 2011, the Federal Geographic Data Committee (FGDC) Steering Committee voted to endorse the Federal Trail Data Standards (FTDS). The FTDS enable national, regional, state, and trail-level managers, partners, and the public to use a common and mutually understood terminology for recording, retrieving and applying spatial and tabular information. The FTDS also make it easier for trail information to be accessed and combined by individuals, agencies, or groups. Ease in sharing data improves the ability for enhanced and consistent mapping, inventory, condition assessment, management, budgeting, monitoring, and information retrieval for internal and external needs.<sup>vi</sup>

In Howard County, the effort is underway to develop a trails database based on Federal Geographic Data Committee standards. Using the same standard for all trails data will allow land managers and recreational users throughout the county to access and use the data regardless of administrative boundary.

Trail Attributes	Trail Class 3 Developed/Improved Trail	Trail Class 4 Highly Developed Trail	Trail Class 5 Fully Developed Trail
<b>Tread &amp; Traffic Flow</b>	<ul style="list-style-type: none"> <li>🚶 Tread obvious and continuous</li> <li>🚶 Width accommodates unhindered one-lane travel (occasional allowances constructed for passing)</li> <li>🚶 Typically native materials</li> </ul>	<ul style="list-style-type: none"> <li>🚶 Tread wide and relatively smooth with few irregularities</li> <li>🚶 Width may consistently accommodate two-lane travel</li> <li>🚶 Native or imported materials</li> <li>🚶 May be hardened</li> </ul>	<ul style="list-style-type: none"> <li>🚶 Width generally accommodates two-lane and two-directional travel, or provides frequent passing turnouts</li> <li>🚶 Commonly hardened with asphalt or other imported material</li> </ul>
<b>Obstacles</b>	<ul style="list-style-type: none"> <li>🚶 Obstacles infrequent</li> <li>🚶 Vegetation cleared outside of trailway</li> </ul>	<ul style="list-style-type: none"> <li>🚶 Few or no obstacles exist</li> <li>🚶 Grades typically &lt;12%</li> <li>🚶 Vegetation cleared outside of trailway</li> </ul>	<ul style="list-style-type: none"> <li>🚶 No obstacles</li> <li>🚶 Grades typically &lt;8%</li> </ul>
<b>Constructed Features &amp; Trail Elements</b>	<ul style="list-style-type: none"> <li>🚶 Trail structures (walls, steps, drainage, raised trail) may be common and substantial</li> <li>🚶 Trail bridges as needed for resource protection and appropriate access</li> <li>🚶 Generally native materials used in Wilderness</li> </ul>	<ul style="list-style-type: none"> <li>🚶 Structures frequent and substantial</li> <li>🚶 Substantial trail bridges are appropriate at water crossings</li> <li>🚶 Trailside amenities may be present</li> </ul>	<ul style="list-style-type: none"> <li>🚶 Structures frequent or continuous; may include curbs, handrails, trailside amenities, and boardwalks</li> <li>🚶 Drainage structures frequent; may include culverts and road-like designs</li> </ul>
<b>Signs</b>	<ul style="list-style-type: none"> <li>🚶 Regulation, resource protection, user reassurance</li> </ul>	<ul style="list-style-type: none"> <li>🚶 Wide variety of signs likely present</li> <li>🚶 Informational signs likely (outside of Wilderness)</li> </ul>	<ul style="list-style-type: none"> <li>🚶 Wide variety of signage is present</li> <li>🚶 Information and interpretive signs likely</li> </ul>

	<ul style="list-style-type: none"> <li> Directional signs at junctions, or when confusion is likely</li> <li> Destination signs typically present</li> <li> Informational and interpretive signs may be present outside of Wilderness</li> </ul>	<ul style="list-style-type: none"> <li> Interpretive signs possible (outside of Wilderness)</li> <li> Trail Universal Access information likely displayed at trailhead</li> </ul>	<ul style="list-style-type: none"> <li> Trail Universal Access information is typically displayed at trailhead</li> </ul>
--	---	---	--

Trail Class descriptions define “typical” attributes, and exceptions may occur for any attribute. Apply the Trail Class that most closely matches the Managed Use for that trail. User-specific design criteria will account for the Trail Class. For specific Design Parameters, refer to the Howard County Department of Recreation & Parks Trails Manual and other applicable Howard County references referred to herein.

## **APPENDIX VI: Trail Signage and Wayfinding**

Please refer to the Howard County Department of Recreation & Parks  
2016 Howard County Trail and Shared Use Path Sign Design Guidelines

<https://www.howardcountymd.gov/Departments/Recreation-and-Parks/FormsandPublications>

For more information, please contact the Natural Resource Conservation Manager, Brenda Belensky  
(410) 313-4724 or [bbelensky@howardcountymd.gov](mailto:bbelensky@howardcountymd.gov)

## **APPENDIX VII: Typical Design Guides For Planning, Construction and Maintenance**

The following sheets are available through the Howard County Department of Recreation & Parks. For more information, please contact the Natural Resource Conservation Manager, Brenda Belensky (410) 313-4724 or [bbelensky@howardcountymd.gov](mailto:bbelensky@howardcountymd.gov)

### **SHEET ONE**

- Trail Corridor Clearing Limits
- Full Bench Cut (Side Hill) Natural Surface Trail
- Grade Reversal/ Dip Perspective
- Grade Reversal/ Dip

### **SHEET TWO**

- Bog Bridge/ Puncheon
- Bog Bridge/ Puncheon Section
- Stone Turnpike Plan View
- Crowned Tread with Stone Turnpike

### **SHEET THREE**

- Stone Steps
- Stone Steps Elevation
- Culvert Pipe with Crowned Tread
- Culvert Detail Side View

### **SHEET FOUR**

- Crushed Stone Tread with Cribwall
- Crushed Stone Tread Single Stone Cribwall
- Crowned Tread with Uphill Swale
- Gargoyle/ Coping Stones

### **SHEET FIVE**

- Timber Cribbed Steps Plan View
- Timber Cribbed Steps
- Elevated Timber Steps

### **SHEET SIX**

- Drainage Ditch
- Drainage Ditch Plan View
- Stone Paving
- Stone Paving Plan View

## APPENDIX VIII: Trail Bridges

Current bridge plans are available through the Howard County Department of Recreation & Parks. For more information, please contact the Natural Resource Conservation Manager, Brenda Belensky (410) 313-4724 or [bbelensky@howardcountymd.gov](mailto:bbelensky@howardcountymd.gov)

## APPENDIX IX: Terms and Definitions

The following trail-related definitions are utilized frequently in the planning, design, construction, and management of trails. They are derived from several sources, including the USDA Forest Service ([www.fs.fed.us](http://www.fs.fed.us)); the United States Access Board ([www.access-board.gov](http://www.access-board.gov)); the Federal Highways Recreational Trails Program ([www.fhwa.dot.gov](http://www.fhwa.dot.gov)); the National Trails Training Partnership ([www.americantrails.org/nttp/](http://www.americantrails.org/nttp/)); and the Pennsylvania Department of Conservation and Natural Resources ([www.dcnr.state.pa.us](http://www.dcnr.state.pa.us)).

- **AASHTO.** American Association of State Highway Transportation Officials
- **AASHTO Guide.** *AASHTO Guide for the Planning, Design, and Operation of Bicycle Facilities*
- **ABA.** Architectural Barriers Act.
- **ABAAS.** Architectural Barriers Act Accessibility Standards.
- **Accessible.** In compliance with the accessibility guidelines at the time the facility or other constructed feature was built or altered.
- **Access Board.** U.S. Architectural and Transportation Barriers Compliance Board.
- **Accessibility Evaluation Survey.** Comparing each portion of a structure to the accessibility standards and recording compliance and deficiencies.
- **Accessible Facilities.** Facilities that comply with the accessibility guidelines.
- **ADA.** Americans with Disabilities Act.
- **ADAS.** 2010 ADA Standards for Accessible Design.
- **Alteration (trail).** A change in the original purpose, intent, function or design of a trail.
- **Alteration (recreation site, building, or facility).** A change to a portion of a recreation site, building, or facility that is addressed by the accessibility guidelines and that affects the usability of the site, building, or facility.
- **BMP.** Best Management Practices.
- **Conditions for Departure.** Specific circumstances found in natural environments that may make it difficult to comply with the accessibility guidelines.
- **Construction.** Building a new trail, recreation site, or facility where there was none before.
- **Constructed Feature.** A constructed element associated with a trail that provides support for trail users, but is not a part of the trail tread. Examples include overnight shelters, toilets, fire rings, picnic tables, and tent pads.

- **Cross Slope.** The percentage of rise to length when measuring the trail tread from edge to edge perpendicular to the direction of travel. *Typical Cross Slope* is normally encountered cross slope found along the length of a trail. Measurement intervals become more frequent as the trail class increases.
- **Disability.** A medically definable condition that causes a limitation in one or more major life activities such as walking, seeing, hearing, speaking, breathing, thinking, and so forth.
- **Design Parameters.** The designed use that controls the geometric design of a trail and determines the level to which it should be maintained
- **Designed Use.** The managed use of a trail that requires the most demanding design, construction, and maintenance parameters and that, in conjunction with the applicable trail class, determines which design parameters will apply to a trail. There is only one designed use of a trail. Feasible. Can be accomplished with a reasonable amount of effort or with customary practices.
- **Firm and Stable Surface.** A surface that is not noticeably distorted or compressed and that doesn't shift during the passage of a device that simulates a person using a wheelchair.
- **FHWA.** U.S. Department of Transportation Federal Highway Administration.
- **Full Bench (construction).** Trail professionals almost always prefer *full-bench* construction. A full bench is constructed by cutting the full width of the tread into the hillside and casting the excavated soil as far from the trail as possible. Full-bench construction requires more excavation and leaves a larger backslope than partial-bench construction, but the trail bed will be more durable and require less maintenance. You should use full-bench construction whenever possible.<sup>vii</sup>
- **Guardrail.** A railing designed to protect people from accidentally falling off an edge where the immediate dropoff is over 30 inches.
- **Handrail.** A narrow railing to be grasped with the hand for support.
- **Hiker/Pedestrian Trail.** A trail that is designed, constructed, and maintained for hiker/pedestrian use (see Design Parameters) or that is actively managed for hiker/pedestrian use (see *Managed Use*).
- **Interagency Trail Data Standards (ITDS).** National Trail Data Standards agreed to by the U.S. Department of Agriculture Forest Service and the U.S. Department of the Interior Bureau of Land Management, Fish and Wildlife Service, National Park Service, and Bureau of Reclamation.
- **Limiting Factor.** An extreme, uncorrectable environmental barrier that makes the trail beyond the barrier unreachable for many people with mobility limitations.
- **Maintenance.** Routine or periodic repair of existing trails, recreation sites, or facilities. Maintenance doesn't change the original purpose, intent, or function of a facility. Maintenance includes but isn't limited to:
  - Repairing or replacing deteriorated, damaged, or vandalized trails, facilities, or components, such as repainting, removing graffiti, and repairing or replacing components

of facilities with new components similar to the original ones. Components can be sections of bridges or boardwalks, signs, fencing and railings, siding, windows, and roofing.

- Removing debris and vegetation, such as fallen trees or broken branches; clearing encroaching vegetation from trails, pathways, lawns, or landscaped areas; and removing rock slides.
- Maintaining trail tread and access routes, such as filling ruts, reshaping a trail bed, replacing or reshaping surfacing material, repairing washouts, installing riprap to retain cut and fill slopes, constructing retaining walls or cribbing to support trail tread, and repairing concrete or asphalt paving.
- Performing erosion control and drainage work, such as replacing or installing drainage dips or culverts and realigning sections of trail to reduce erosion or avoid boggy areas.<sup>viii</sup>
- **Managed Use.** The managed use of a trail that requires the most demanding design, construction, and maintenance parameters and that, in conjunction with the applicable trail class, determines which design parameters will apply to a trail. There is only one designed use of a trail.
- **OPDMD.** Other Power-Driven Mobility Device, which is defined in the 2011 U.S. Department of Justice regulations interpreting the ADA.
- **Outdoor Guidelines**—The *Outdoor Developed Areas Accessibility Guidelines*, September 26, 2013, issued pursuant to the Architectural Barriers Act.
- **Outdoor Recreation Access Route (ORAR).** A continuous, unobstructed path for pedestrian use that connects elements in a picnic area, in a campground, or at a trailhead. See Chapter 1016 of the Outdoor Guidelines.
- **Program Accessibility.** Providing all people, including people with disabilities, the opportunity to participate in a program—an activity in which someone may participate or the reason someone visits an area.
- **Point of Deviation.** The location on a trail where one or more technical provisions in the ADA Trail Accessibility Guidelines cannot be met due to the presence of a condition for departure enumerated therein.
- **Prominent Feature.** A natural, cultural, or historic feature located along or adjacent to a trail that is determined by a trail designer or manager to have national, regional, or local distinction or significance. A prominent feature may be the focal point, main attraction, or destination of a trail, or it may simply be an interesting secondary feature. Examples include but are not limited to boulder outcrops, waterfalls, groupings of old or unique trees or other vegetation, vistas that may or may not be part of a developed overlook, and cultural or historic structures.
- **Provisions.** Sections of accessibility guidelines and standards that explain what is required for specific situations and facilities (parking, picnic tables, trails, and so forth).
- **Protruding Object.** An object, such as a tree, branch, or rock ledge, that extends into a trail from beside or above it.
- **PROW Guidelines.** Proposed Accessibility Guidelines for Pedestrian Facilities in the Public Right-of-Way.



- **Public Right-of-Way.** Public land acquired for or dedicated to transportation purposes, or other land where there is a legally established right for use by the public for transportation purposes.
- **Recreation Site.** A discrete area that provides recreation opportunities, receives use, and requires a management investment to operate and/or maintain to standard.
- **Scoping.** The term used for the process of figuring out when, how much, and where the guidelines apply.
- **Scoping Requirement.** Specification of where, when, and how much of a constructed feature must be accessible to comply with the ADA Trail Accessibility Guidelines.
- **Setting.** The term used to describe the natural surroundings of a trail or recreation area.
- **Slope Ratio.** A ratio of vertical distance to horizontal distance, or “rise” to “run.”
- **Surface.** The top layer of ground on a recreation site, accessible route, shared use path, or trail.
  - Firm. Not noticeably distorted or compressed by the passage of a device that simulates a trail user in a wheelchair. Surface firmness should be determined and documented during the planning process for the seasons for which a trail is managed, under normally occurring weather conditions.
  - Stable. Not permanently affected by normally occurring weather conditions and able to sustain normal wear and tear caused by the uses for which a trail is managed, between planned maintenance cycles.
- **TAI.** Trail Access Information.
- **Technical Provision.** State the specific numbers, conditions, and measurements that are required (percent that must comply, dimensions, reach ranges, grades, trail width, and so forth to meet accessibility guidelines).
- **Trail.** A route that is designed, constructed, or designated for recreational pedestrian use or provided as an pedestrian alternative to vehicular routes within a transportation system. A trail is not an outdoor recreation access route (ORAR).
- **Trail Accessibility Guidelines.** Chapter 1017 of the Outdoor Guidelines.
- **Trail Class.** The prescribed scale of trail development, indicating the intended design and management standards for a trail.
- **Trail Constructed Feature.** A Trail Constructed Feature is a constructed feature that functions as part of the trail tread. Examples include puncheon, trail bridges, boardwalks, waterbars, and switchbacks.
- **Trail Grade.** The consistent vertical distance of ascent or descent of a trail expressed as a percentage of its length, commonly measured as a ratio of rise to length.
- **Trailhead.** A site designed and developed to provide staging for trail use. The following do not constitute a trailhead:
  - Junctions between trails where there is no other access.

- Intersections where a trail crosses a road or users have developed an access point, but no improvements have been provided beyond minimal signage for public safety.
- **Trail Segment.** The portion of a trail being planned, evaluated, or constructed.
- **Trail Terminus.** The beginning or ending point of a trail or trail segment, where a trail assessment or trail work begins or ends.
- **Tread.** The travel surface of the trail.
- **Tread, trail (treadway).** The surface portion of a trail upon which users travel, excluding backslope, ditch, and shoulder. Tread surfaces can consist of native soil material, aggregate, asphalt, concrete, recycled materials and native materials that are modified with soil stabilizers.
- **Tread Width.** The visible trail surface measured perpendicular to the direction of travel.
  - *Clear Tread Width.* The width of the usable trail tread and adjacent usable surface.
  - *Minimum Tread Width.* The width of the usable part of the tread width at the narrowest point on a trail.
  - *Minimum Trail Width.* The width of the trail tread and the adjacent usable surface at the narrowest point on a trail.
- **Universal Access.** Programs and facilities designed to be usable by all people, to the greatest extent possible, without separate or segregated access for people with disabilities.
- **Wheelchair.** A device including one that is a battery-powered, that is designed solely for use by a mobility-impaired person for locomotion and that is suitable for use in an indoor pedestrian area. A person whose disability requires use of a wheelchair or mobility device may use a wheelchair or mobility device that meets this definition anywhere foot travel is permitted.

## ENDNOTES

---

- <sup>i</sup> The full name of the U.S. Access Board is the U.S. Architectural & Transportation Barriers Compliance Board. It developed the proposed Outdoor Developed Areas Accessibility Guidelines (i.e., the Outdoor Guidelines) through regulatory negotiation, which was a process of face-to-face negotiations among representatives of interested groups, with the goal of arriving at a consensus that then went through a public comment period. The committee tasked with developing the proposed rule was called the Regulatory Negotiation Committee on Outdoor Developed Areas Accessibility Guidelines.
- <sup>ii</sup> The guidelines added new sections to the ABA relating to the following recreation facilities constructed or altered by or on behalf of the federal government:
- ABA Chapter 2: Scoping Requirements
    - F244 Camping Facilities
    - F245 Picnic Facilities
    - F246 Viewing Areas
    - F247 Trails
    - F248 Beach Access Routes
  - ABA Chapter 10: Recreation Facilities
    - 1011 Outdoor Constructed Features
    - 1012 Parking Spaces within Accessible Camping Units and Picnic Units and Pull-Up Spaces at Recreational Vehicle Dump Stations
    - 1013 Tent Pads and Tent Platforms
    - 1014 Camp Shelters
    - 1015 Viewing Areas
  - ABA Chapter 1016: Outdoor Recreation Access Routes
  - ABA Chapter 1017: Trails
  - ABA Chapter 1018: Beach Access Routes
  - ABA Chapter 1019: Conditions for Exceptions
- <sup>iii</sup> A complete copy of the Outdoor Guidelines (ABA Accessibility Guidelines, Outdoor Developed Areas, published in the Federal Register on September 26, 2013) is available from the U.S. Access Board at <http://www.access-board.gov>.
- <sup>iv</sup> A pdf copy of the ABA's May 2014 publication which provides full informational guidance for Federal entity trails, camping and picnic facilities, viewing areas and beach access is available at <http://www.access-board.gov>.
- <sup>v</sup> Source: *The Outdoor Recreation Alliance of the 7 Rivers Region*, La Crosse, Wisconsin, <http://www.naturesplacetoplay.com/closing-and-reclaiming-damaged-trails.html>
- <sup>vi</sup> For complete history and latest updates related to the FTDS, see the Federal Geographic Data Committee (FGDC) link; <http://www.fgdc.gov/standards/projects/FGDC-standards-projects/trail-data-standard/trail-data-standards>
- <sup>vii</sup> *Trail Construction & Maintenance Notebook*, USDA Forest Service, 2007, 0723-2806-MTDC.
- <sup>viii</sup> *Accessibility Guidebook for Outdoor Recreation and Trails*, USDA Forest Service Technology & Development Program, Publication 2300–Recreation August 2012 1223–2806P–MTDC, p. 29.