

GENERAL PLAN UPDATE - HOCO BY DESIGN

PLANNING BOARD WORKSHOP

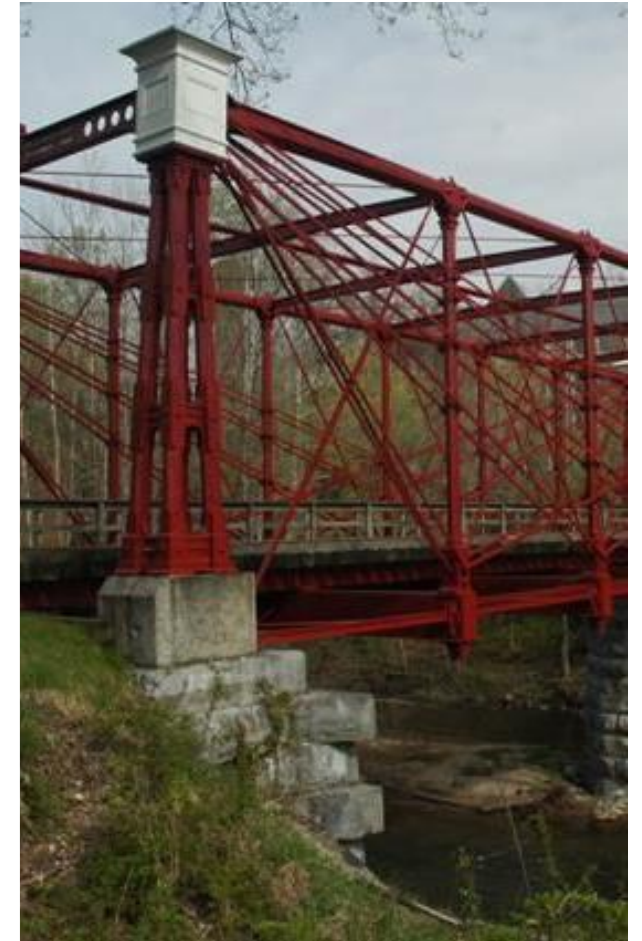
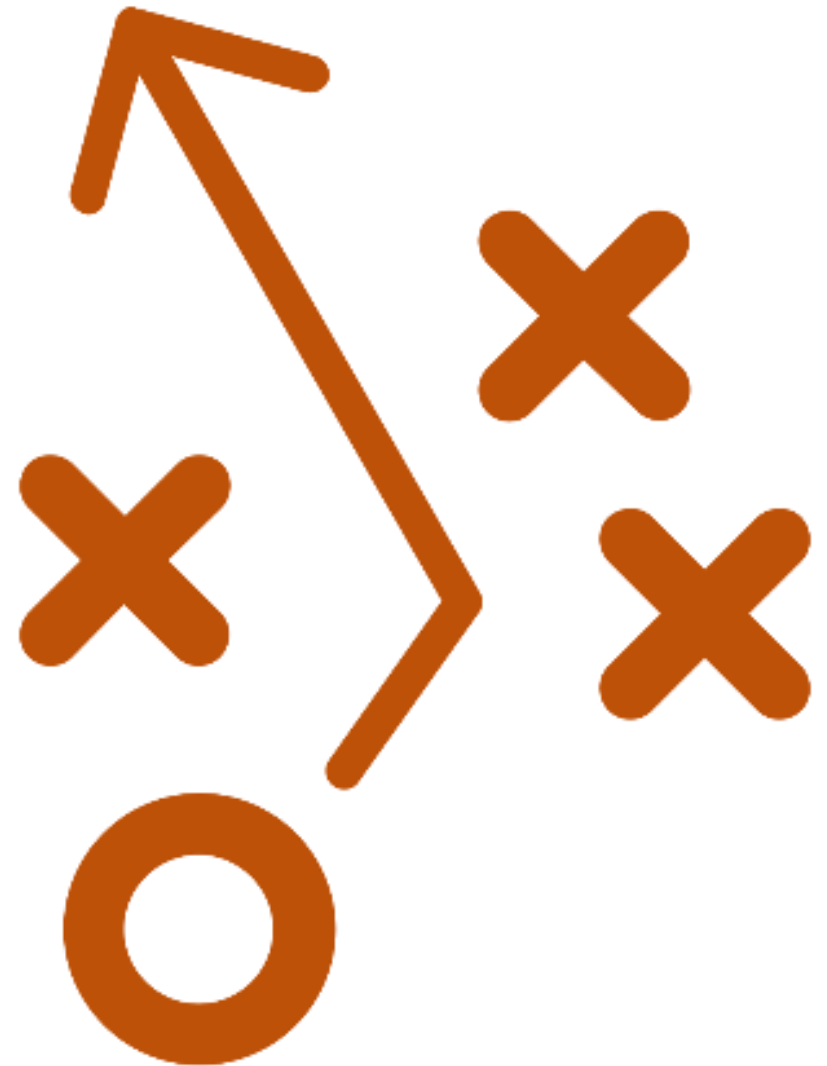

APRIL 9, 2020

- ✔ **WHAT IS A GENERAL PLAN?**
- ✔ **PROJECT BACKGROUND**
- ✔ **WHERE DO WE GO FROM HERE?**
- ✔ **PRELIMINARY STRATEGIC FRAMEWORK DISCUSSION**



USE OUR TIME WISELY THIS EVENING

MEET THE MAJOR TEAM MEMBERS



MATT NOONKESTER



JERAH SMITH

Mahan, Rykiel & Associates, Inc.

COMMUNITY CHARACTER

Sabra and Associates, Inc.

TRANSPORTATION

Agriculture & Community Design Services

AGRICULTURE

Stantec Urban Places

COMMUNITY CHARACTER

RCLCO

DEMOGRAPHIC & MARKET ANALYSIS

TPUDC

BRANDING & COMMUNITY CHARACTER

Biohabitats

ENVIRONMENTAL RESOURCES

Things you will tell us about the community and where you see it in the future.

Opportunities in the County that align with community value and are supported by data analysis.

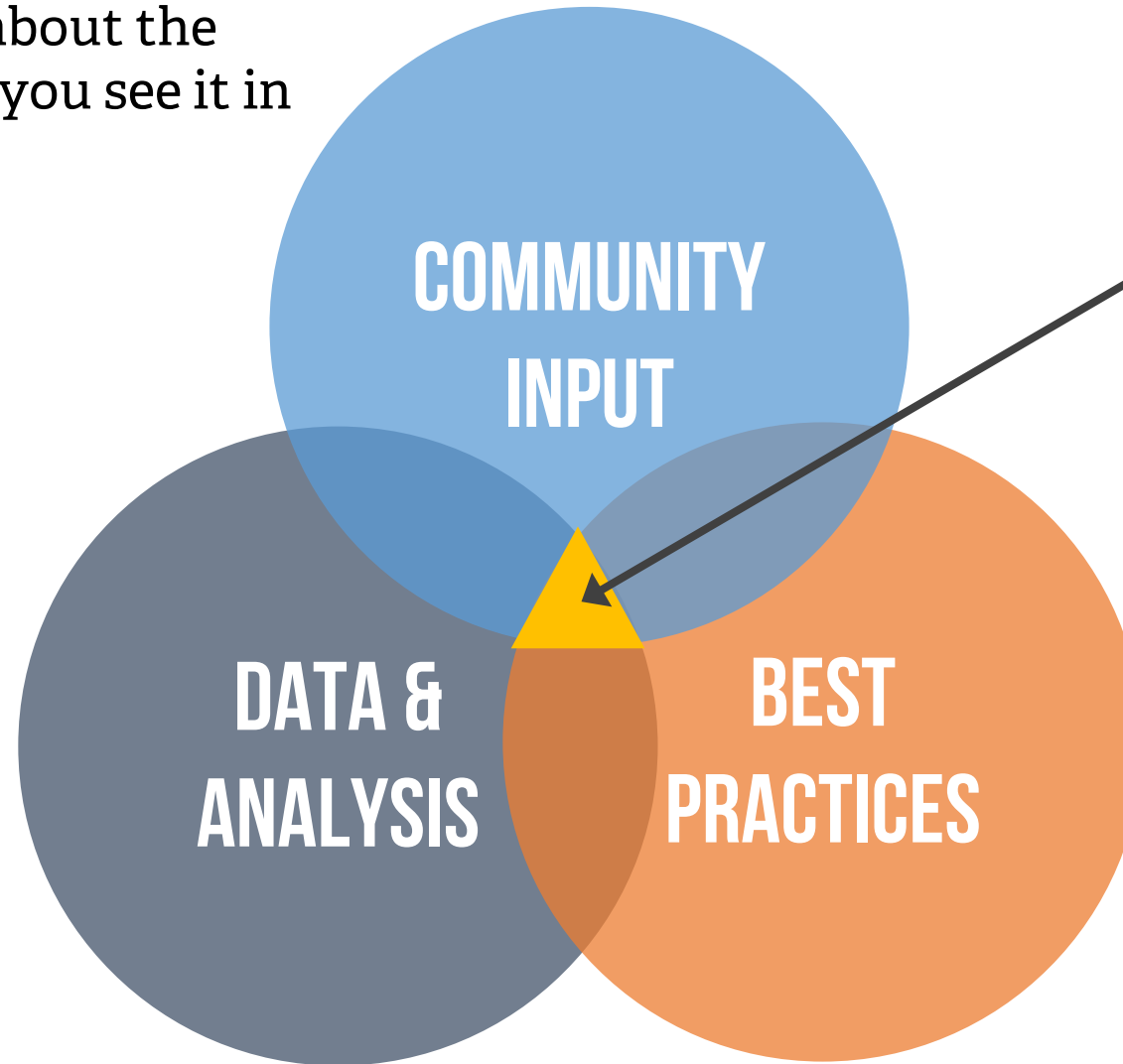

What we will learn about infrastructure, economy, new trends, etc.

Experience of County staff and the consultants they bring from working in Howard County and elsewhere.

COMBINE OUR STRENGTHS IN THE PLANNING PROCESS

WHAT IS A GENERAL PLAN?

A required document that must be updated every 10 years (i.e., 1960, 1971, 1982, 1990, 2000, 2012).

A statement of county development and land use policy. The plan includes policies and consists of maps, goals, and implementing actions.

A framework for the future. Provides a clear blueprint for how Howard County should grow and be preserved in the future.

A tool for long range coordination. The plan looks 20 to 30 years into the future and guides a wide range of decisions related to land use, transportation, open space, agriculture, community facilities and services, community character, historic preservation, housing and neighborhoods and economic development, among others.

A guide for related public physical improvement. The plan guides public investment such as water, sewer and transportation.



WHAT IS A GENERAL PLAN?

A regulatory tool. Land development is regulated by the County's zoning and subdivision requirements, which implement the General Plan.

Direct market intervention. It does not attempt to replace market forces of supply and demand. It helps shape and channel market forces by establishing certain policy guidance to manage development.

An instrument of immediate change. Change will occur incrementally as the plan is implemented.

A static policy tool. Good planning requires continual review of implementation successes and challenges, citizen desires so that the plan can be adjusted as needed.

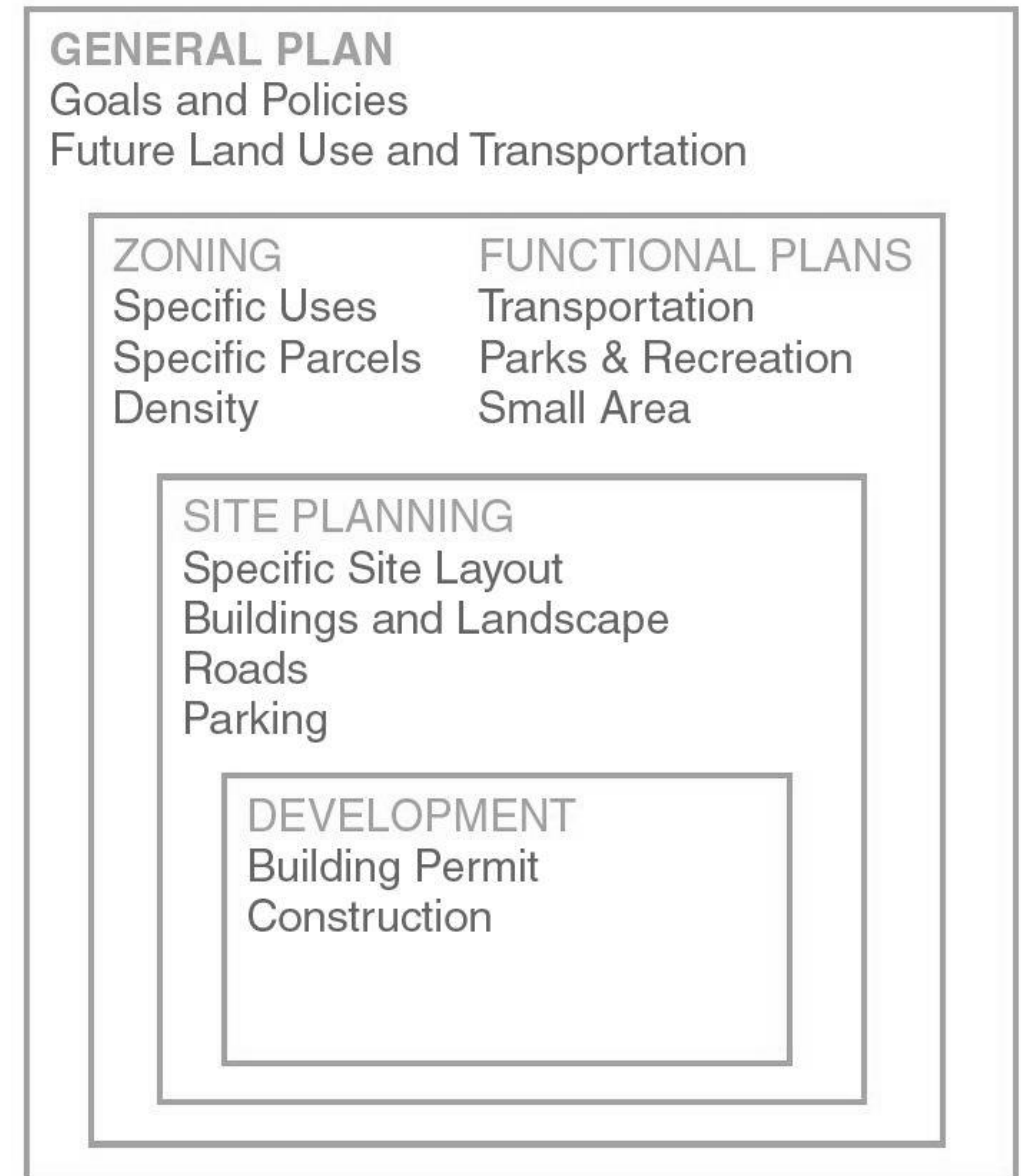

WHAT A GENERAL PLAN IS NOT...

General Plan History



HOWARD COUNTY GENERAL PLAN HISTORY

LEGAL ORIGINS OF THE STRATEGIC FRAMEWORK

HOWARD COUNTY CODE TITLE 16, SUBTITLE 9, 16.900(J)(4)

(4) General plan guidelines:

(i) *Preparation of guidelines.* Within five years from the adoption of this comprehensive rezoning plan, the Planning Board shall **prepare general guidelines** to be used by the Department of Planning and Zoning in the preparation and/or revision of the general plan.

(ii) *Adoption of guidelines.* The County Council shall adopt the guidelines by resolution prior to the formulation of the general plan utilizing these guidelines.

STARTING POINT FOR THE GENERAL PLAN UPDATE

PROJECT BACKGROUND

HOWARD COUNTY GENERAL PLAN 2040

PROJECT SCHEDULE

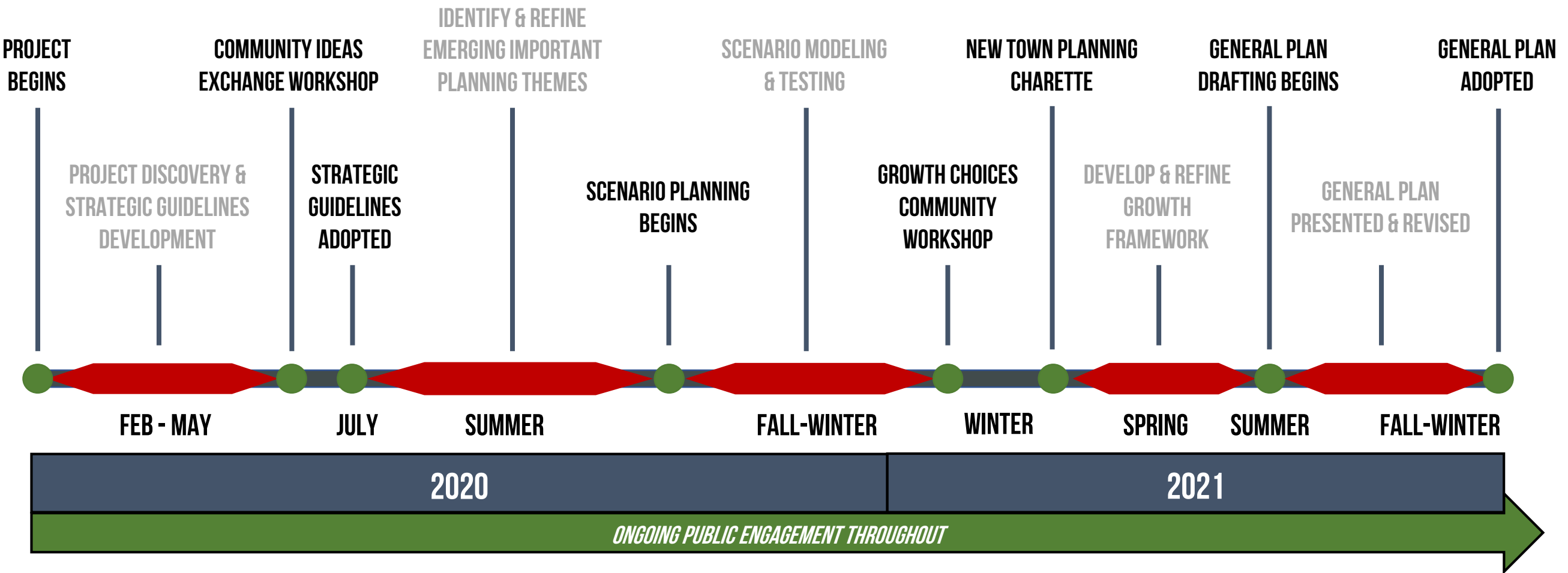

EDUCATE

- ✓ PROJECT EDUCATION CURRICULUM
- ✓ ON-LINE PROJECT ENGAGEMENT
- ✓ RESPONSE TO PUBLIC INQUIRES ABOUT THE PROJECT

INFORM US

- ✓ STAKEHOLDER INTERVIEWS
- ✓ COMMUNITY IDEAS EXCHANGE WORKSHOP
- ✓ ON-THE-TABLE INITIATIVE
- ✓ BETTER COMMUNITIES BOARD GAME

COLLABORATE

- ✓ TECHNICAL ADVISORY TEAM
- ✓ PLANNING ADVISORY COMMITTEE
- ✓ STRATEGIC ADVISORY GROUP
- ✓ GROWTH CHOICES SUMMIT (IN-HOUSE)
- ✓ NEW TOWN FRAMEWORK DESIGN CHARRETTE

FEEDBACK

- ✓ GROWTH CHOICES WORKSHOP
- ✓ DRAFT PLAN RECOMMENDATIONS WORKSHOP
- ✓ POLICY-MAKER BRIEFINGS & HEARINGS

COMPREHENSIVE PARTNERING STRATEGY FOR THE GENERAL PLAN

PROJECT EDUCATION CURRICULUM

ASSEMBLE AND PRESENT A WIDE VARIETY OF MATERIAL TO EDUCATE HOWARD COUNTY DURING THE PROCESS

ONLINE PROJECT ENGAGEMENT

HOCOPYDESIGN.COM SERVES AS THE ONLINE HUB FOR INFORMATION SHARING, ENGAGEMENT AND FEEDBACK

RESPONSE TO PUBLIC INQUIRIES

GET ANSWERS TO YOUR QUESTIONS



EDUCATE: PARTNERING STRATEGY ELEMENT



STAKEHOLDER INTERVIEWS

INTERVIEWS AND SMALL MEETINGS WITH COMMUNITY LEADERS

COMMUNITY IDEAS EXCHANGE WORKSHOP

EVENT TO DISCUSS AND CREATIVELY SHARE IDEAS AND VISION

ON-THE-TABLE INITIATIVE

INFORMAL DISCUSSION GUIDE TO HOST MEETINGS WITH FRIENDS AND FAMILY

BETTER COMMUNITIES BOARD GAME

HOWARD COUNTY-SPECIFIC BOARD (AND ONLINE) GAME ABOUT CONSERVATION AND GROWTH

INFORM US: PARTNERING STRATEGY ELEMENT

TECHNICAL ADVISORY COMMITTEE

COUNTY DEPARTMENT COORDINATION & PARTNERING

PLANNING ADVISORY COMMITTEE

APPOINTED BODY TO PROVIDE LOCAL PERSPECTIVES ON THE PLANNING PROCESS

STRATEGIC ADVISORY GROUP

THEME-BASED GROUPS WITH EXPERTS GIVING US THEIR OPINIONS

GROWTH CHOICES SUMMIT (IN-HOUSE)

PROJECT TEAM MEMBERS JOINTLY DEVELOP ALTERNATIVE FUTURE SCENARIOS

NEW TOWN FRAMEWORK DESIGN CHARETTE

EVENTS HOSTED TO DRILL DOWN ON FOCUS AREAS WITHIN NEW TOWN



COLLABORATE: PARTNERING STRATEGY ELEMENT

GROWTH CHOICES WORKSHOP SERIES*

EVENTS TO PRESENT, DISCUSS AND EVALUATE VARIOUS ALTERNATIVE FUTURE SCENARIOS

DRAFT PLAN RECOMMENDATIONS WORKSHOP SERIES*

EVENTS TO PROVIDE INPUT ON VISION, GUIDING PRINCIPLES, FUTURE LAND USE MAP, AND SPECIFIC RECOMMENDATIONS IN THE GENERAL PLAN

POLICY-MAKER BRIEFINGS & HEARINGS

OPPORTUNITIES TO KEEP DECISION MAKERS INFORMED AND HEAR THEIR INPUT



FEEDBACK: PARTNERING STRATEGY ELEMENT

* = INCLUDES OPPORTUNITIES FOR BOTH IN-PERSON & ONLINE ENGAGEMENT

WRITING THE STRATEGIC FRAMEWORK



GENERAL PLAN BACKGROUND

HISTORY, IMPORTANCE, FUNCTION



STRATEGIC FRAMEWORK DEVELOPMENT

RESEARCH & PROCESS

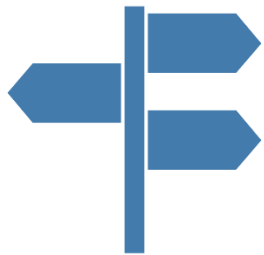

STRATEGIC FRAMEWORK

PROJECT PLAN OVERVIEW, PUBLIC ENGAGEMENT,
OVERARCHING FRAMEWORK, PROCESS FRAMEWORK

COMPONENTS OF OUR **STRATEGIC FRAMEWORK DOCUMENT**



**PROJECT DISCOVERY
& RESEARCH**



PUBLIC ENGAGEMENT PLAN



**BEST
PRACTICES**



**STAKEHOLDER
INTERVIEWS**



**DEVELOPMENT
REGULATIONS
ASSESSMENT**

INFORMING THE STRATEGIC FRAMEWORK

PEOPLE

THE NEEDS & WANTS OF THE COMMUNITY

PLACES

UNIQUE & IDENTIFIABLE SPACES,
DIVERSIFIED DEVELOPMENT STRATEGY

PERFORMANCE

COMMUNITY VALUES, ECONOMIC VITALITY,
FINANCIAL STABILITY, QUALITY-OF-LIFE &
SUPPORTING INFRASTRUCTURE

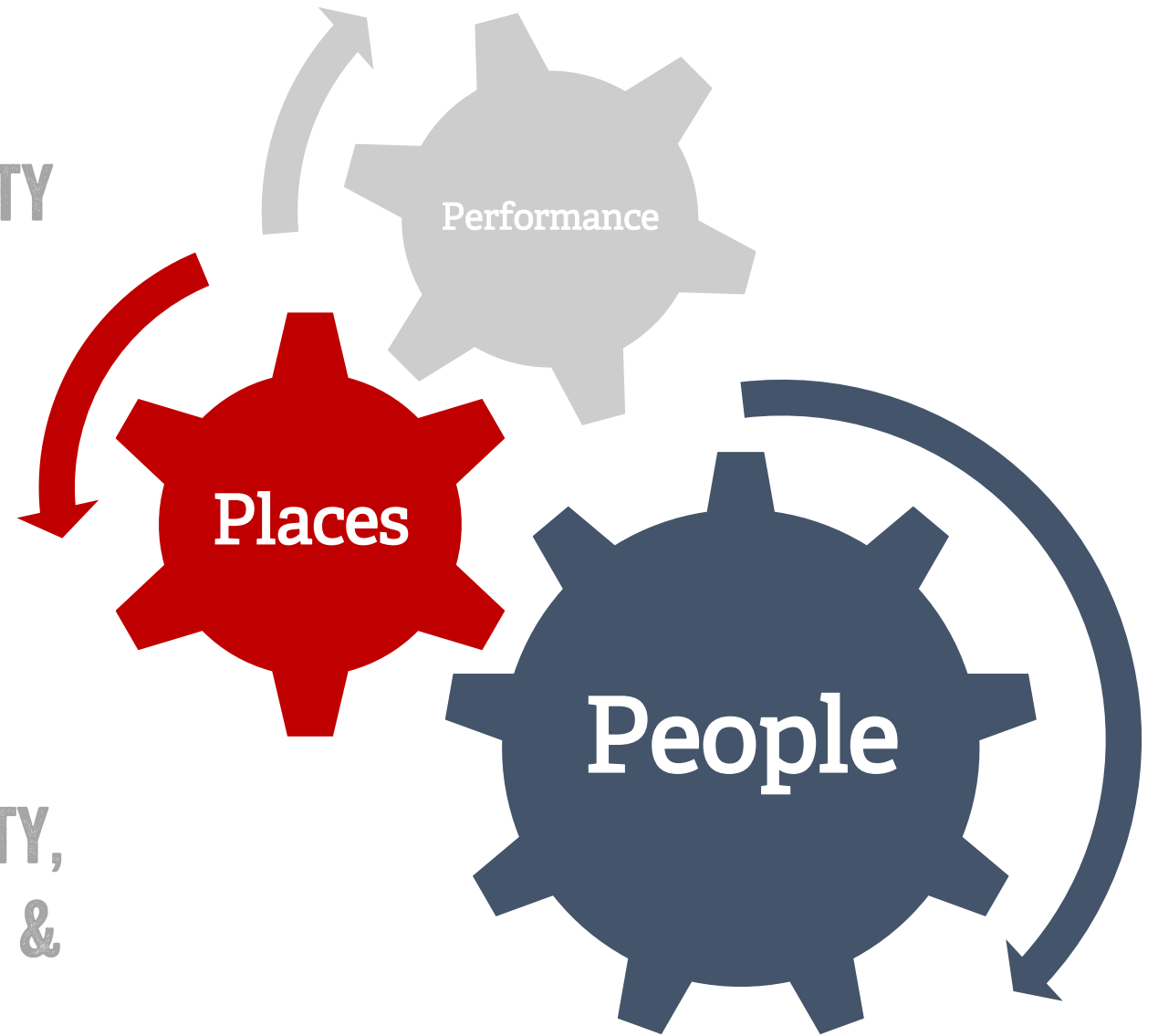

PROCESS FRAMEWORK: HOW WE DO OUR WORK?



AREAS TO PRESERVE



AREAS TO ENHANCE

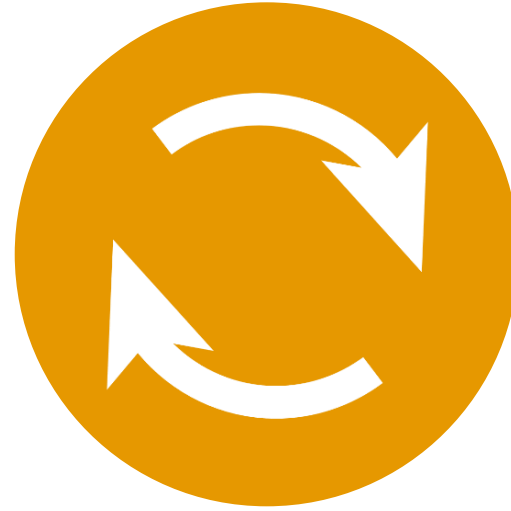

AREAS TO TRANSFORM



AREAS TO STRENGTHEN

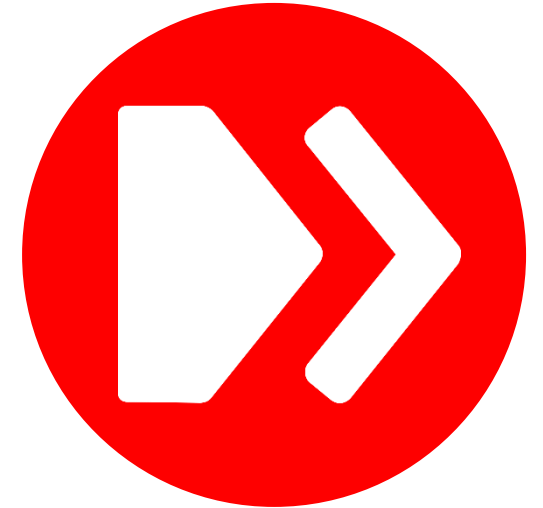

GENERAL MINDSET FOR DEVELOPING THE FRAMEWORK

IT ALL STARTS WITH THE COUNTY'S CHARACTER...

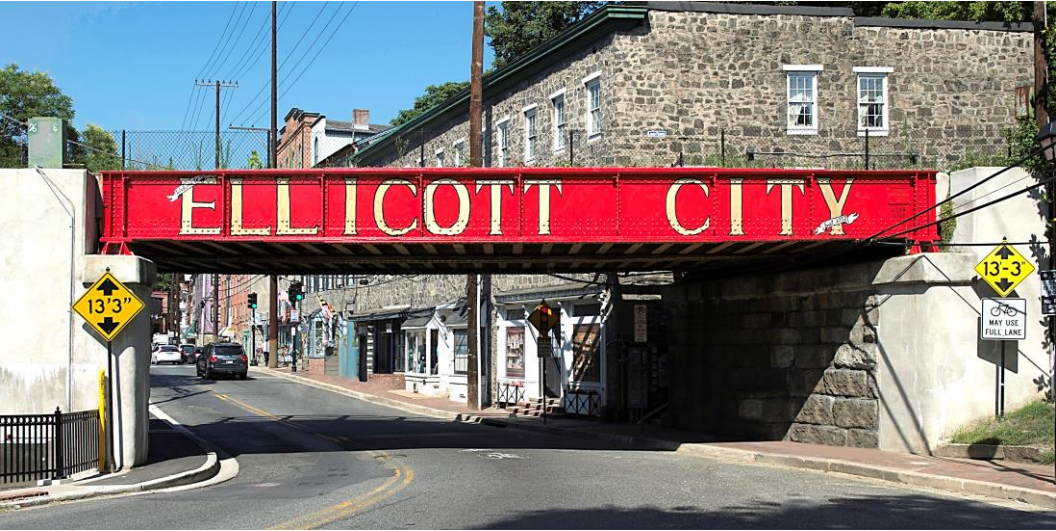

BIG IDEAS TO BRING FORWARD FOR THE GENERAL PLAN

WRITE A DOCUMENT THAT IS A PLAYBOOK...

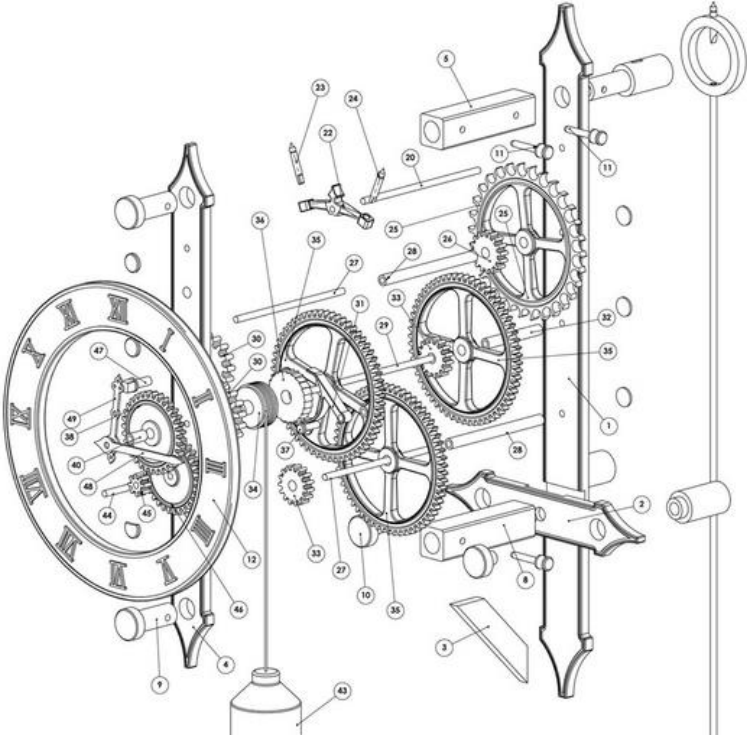

BLUEPRINT APPROACH

A specific plan that serves as a guide for making something else.

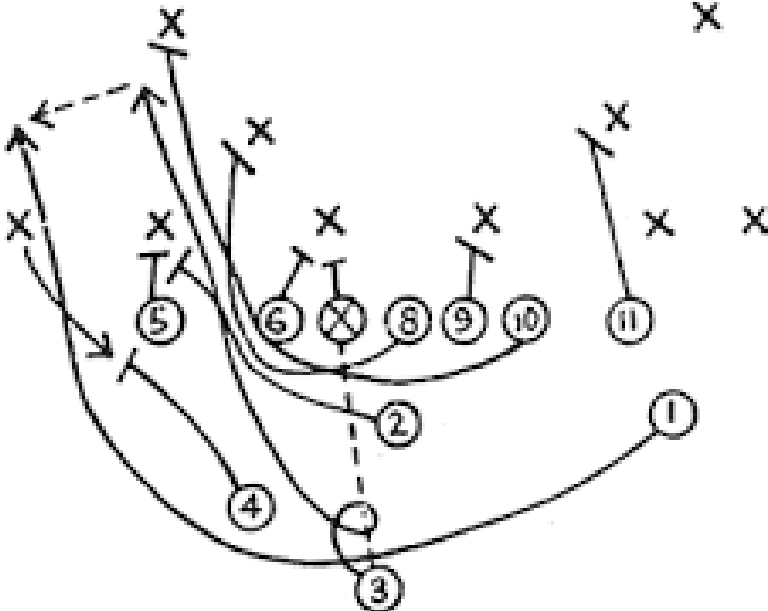

PLAYBOOK APPROACH

A book of different plays that are used by a team in response to changing conditions.

BIG IDEAS TO BRING FORWARD FOR THE GENERAL PLAN

WRITE A DOCUMENT THAT IS A PLAYBOOK...

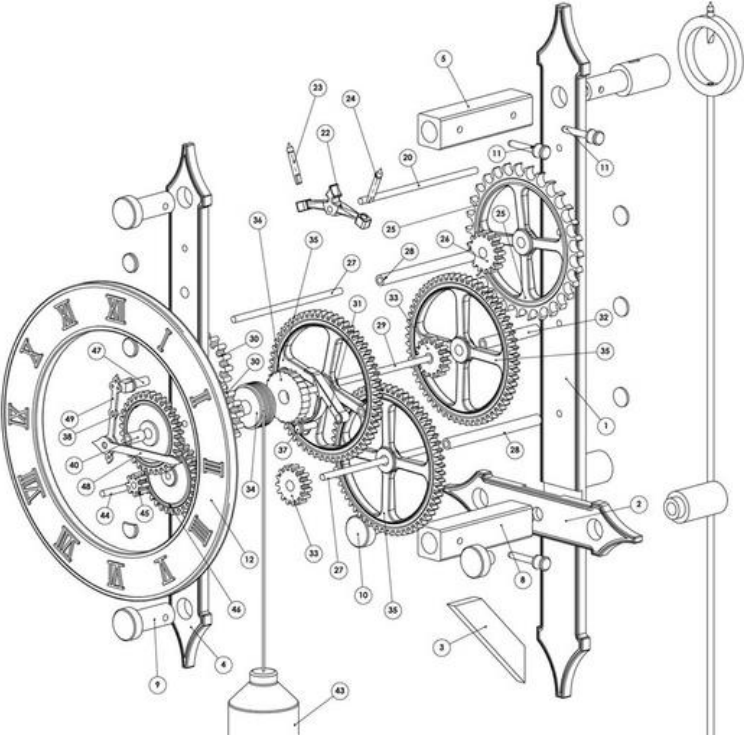

BLUEPRINT APPROACH

A specific plan that serves as a guide for making something else.

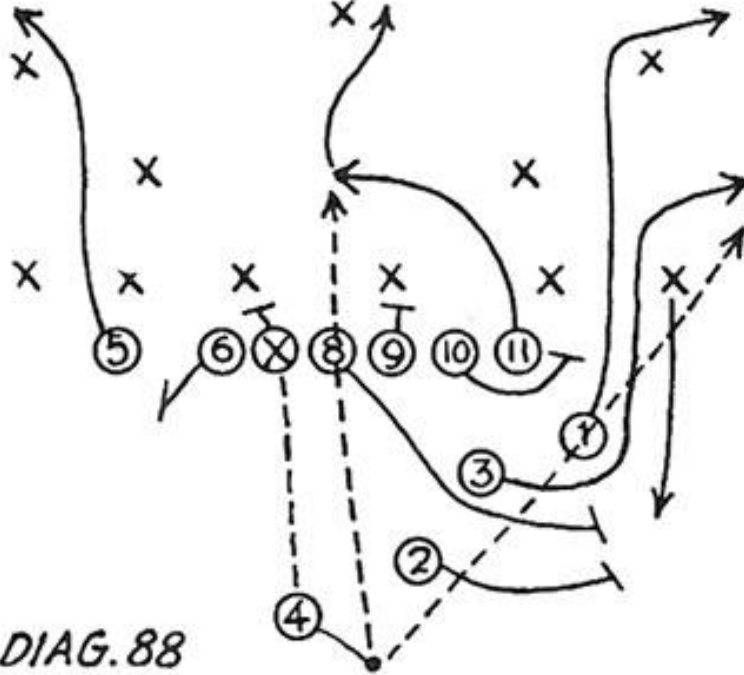

PLAYBOOK APPROACH

A book of different plays that are used by a team in response to changing conditions.

BIG IDEAS TO BRING FORWARD FOR THE GENERAL PLAN

WRITE A DOCUMENT AROUND IMPORTANT THEMES...

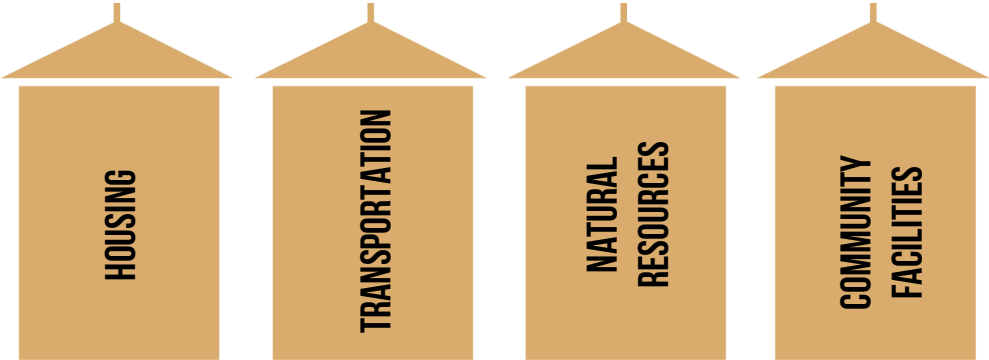

vs.

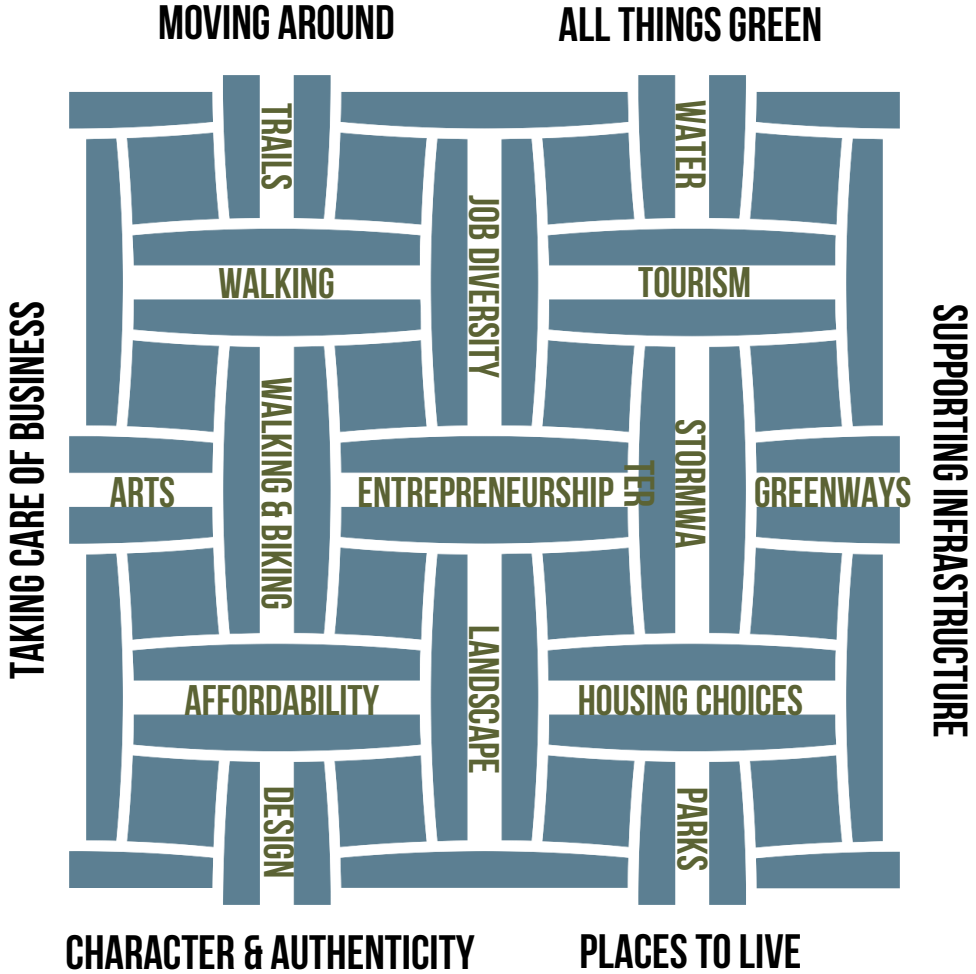

BIG IDEAS TO BRING FORWARD FOR THE GENERAL PLAN

BUILD MORE BRIDGES TO THE UDO...



The General Plan guides growth and conservation decisions early in the process. It clarifies intent, provides a framework of expectations, and directs more-detailed studies, plans, and ordinances to come using high-level vision and general recommendations.

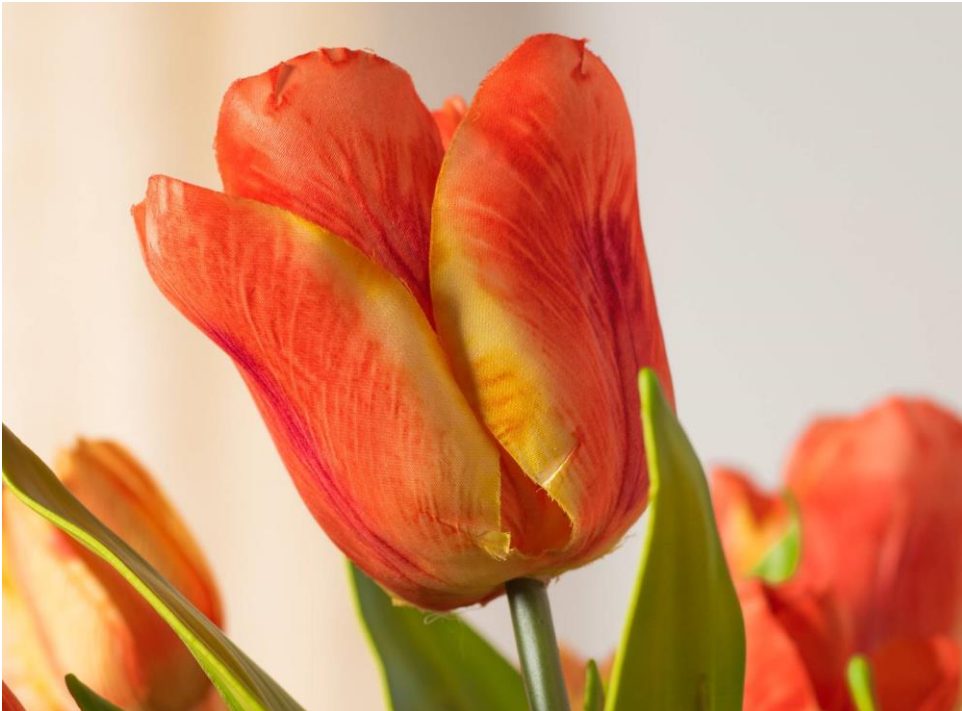

The Unified Development Ordinance implements recommendations in the General Plan using much more detail, and secures commitments for a specific property based on site characteristics, proposed land uses and densities, surrounding development context, and anticipated impacts. A character-based UDO — taking direction from the General Plan — provides new opportunities for the Planning Board and County Council to influence use, design, and character decisions in the zoning process (vs. waiting until the subdivision process).

BIG IDEAS TO BRING FORWARD FOR THE GENERAL PLAN

DOCUMENT-WRITING DISCUSSION

BIG ITEMS FOR OUR DISCUSSION TODAY

What about *PlanHoward 2030* works well now? What doesn't work as well? What would make it better?

What in the General Plan would make your life easier at the dais? What information do you need to know to make confident decisions about future growth and conservation?

When this process is complete and you're looking back, what would you see as a positive outcome?

Who might be under-represented in the planning process?

Do you believe that an organizational framework — Preserve, Enhance, Transform, and Strengthen — is an effective framework for the General Plan process? If not, why?

Is there anything you feel needs to be added to the structure of the document to feel confident in the General Plan process? Is there anything missing?

Do you believe that a process framework focusing on People, Places and Performance is an effective framework for the General Plan process? If not, why?

What did we miss, or what needs to change, before moving forward with the next meeting on MAY 7th?

BIG ITEMS FOR OUR DISCUSSION TODAY



Strategic
Framework
Development

April 2020

Planning
Board
Adoption

May 2020

County
Council
Adoption

June 2020

WHAT'S NEXT

